



Design
Guidelines



Cast DL60

**Print & Cast Design
Guidelines**

The following design rules will help achieve a successful and dimensionally accurate print and cast results, as part of preparing your CAD file ready for print





Design Guidelines

Cast DL60 Design Guidelines

Design Features important for Printing	Values
Minimum hole diameter	0.5 mm
Minimum slot thickness	0.5 mm
Minimum wall thickness	0.3 mm
Overhangs	Successful for overhangs $\leq 60^\circ$
Minimum wall thickness unsupported	Minimum wall thickness unsupported is 0.3mm with maximum height of 10mm.
Scaling Factor	+0.5% XY axis
(Already implemented in Photocentric Studio print profiles)	1.1

Design Features important for Casting	Values
Undercuts	When designing undercuts, ensure they are easily printable and that the ceramic slurry can access all surfaces during shelling. Avoid creating closed cavities where slurry would be trapped or unable to flow.
Sharp corners	Avoid sharp corners. Use fillets of ≥ 1 mm radius to reduce stress concentrations and improve molten metal flow.

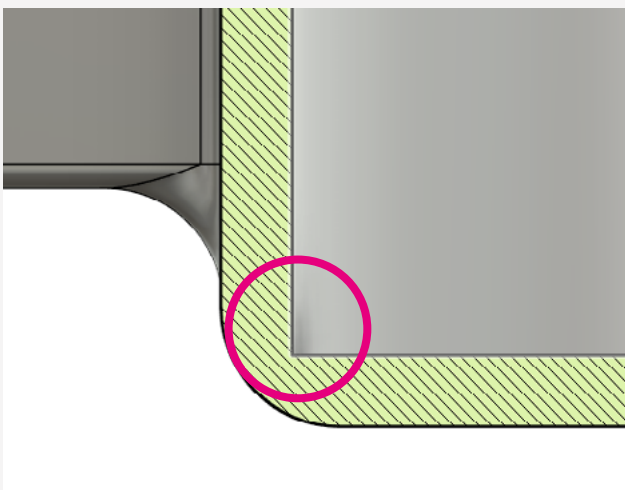

Example of a sharp corner – to be avoided

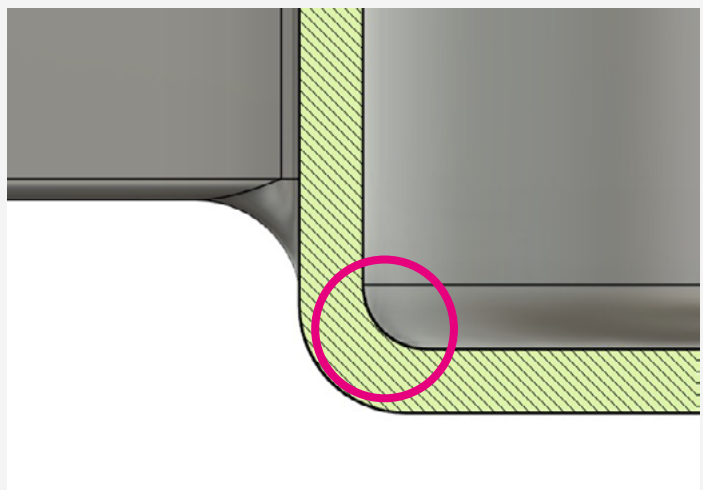

Example of an improved, rounded corner



Design Guidelines



Example of sharp corners – to be avoided

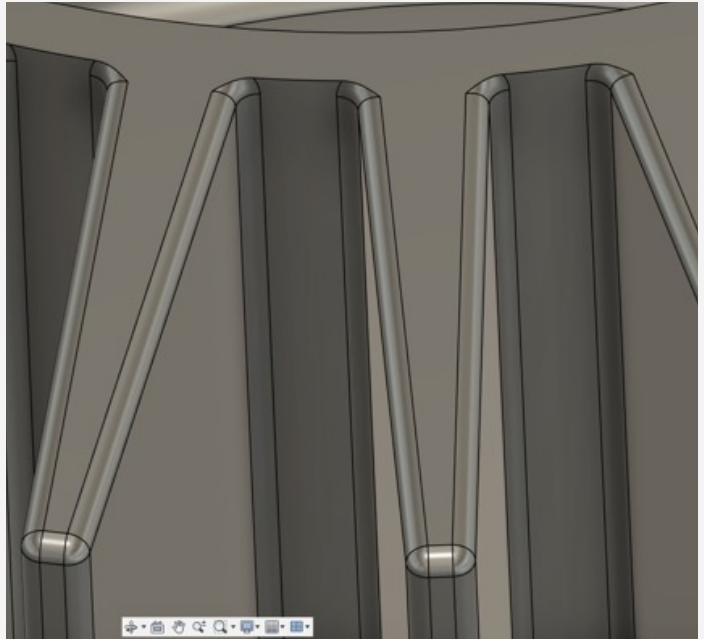

Example of improved, rounded corners

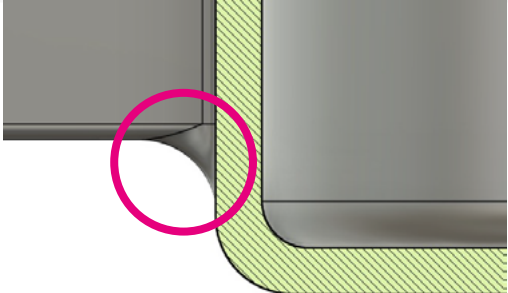
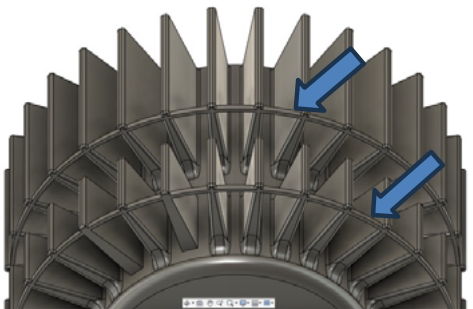
Surface texture	Smoother printed surfaces produce smoother castings. Consider light post-processing of prints, or add a fine texture to your CAD model to achieve a uniform surface finish.
Casting Shrinkage	Account for alloy-specific shrinkage (~1–2.5%). Your foundry can provide exact values.
Thin sections & transitions	Avoid abrupt changes in surface area or rapid thickness transitions; taper the joints to minimise defects and improve flow. 
Text & engravings	Raised text: ≥ 0.5 mm height. Engraved text: ≥ 0.5 mm depth with > 1 mm stroke width.
Design Tip: Supporting Thin Fins	When printing parts such as engine housings with angled thin fins, the fins may deform if not adequately supported. A simple solution is to design a connecting ring at the base of each fin line, which ties the fins together. This keeps the fins straight while reducing the number of supports required. The ring can be easily removed during the support removal stage. 



Design Guidelines

Digital Pattern Preparation Guidelines

Digitally preparing patterns is critical to achieving successful castings. Patterns should be hollowed to minimise the amount of material that needs to burn away.

Less material makes the process more economical, reduces ash residue, and relieves internal pressures from thermal expansion and gas build-up. At the same time, hollowing must not compromise strength. The patterns must remain robust enough to withstand shelling forces or vacuum pressures during flask casting.

High strength and low mass are best achieved by combining thin outer walls with an internal lattice infill. The lattice infill should be designed to maintain parts integrity while allowing fast, efficient draining after printing and washing.

A range of software solutions can assist with hollowing and generating optimised lattice infill structures for investment casting. The following is a step-by-step guide using VoxelDance Additive.

1. Hollowing the models with double walls

Minimum wall thickness	1 mm – thinner walls may not print or cast reliably and are prone to warping during post-curing or casting preparation
Maximum wall thickness	Parts with walls < 2 mm do not need to be hollowed – 2 mm solid walls can burn out successfully
Minimum gap thickness between the walls	1mm meaning minimum hollow-able part thickness is 3 mm –to be successfully and reliably hollowed and allow 1 mm gap between double walls.
Uniform wall thickness	Maintain uniform wall thickness wherever possible to minimise warping, shrinkage, and hot spots. When hollowing a part, ensure there is at least a 1 mm gap between double walls to allow resin to drain properly. Gaps smaller than 1 mm may not drain fully, resulting in solid areas after printing.

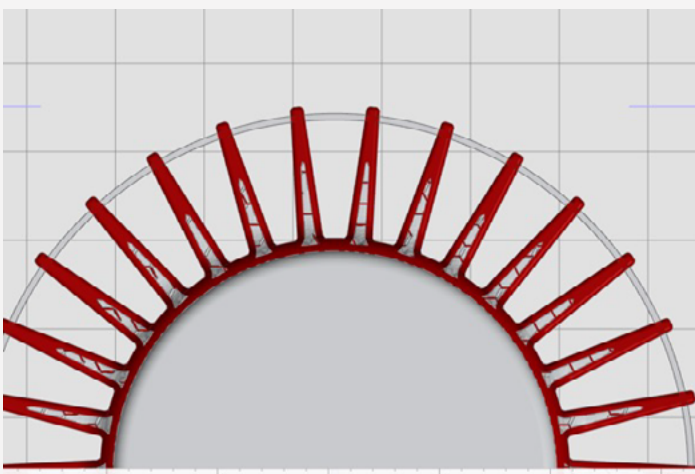

Example- to be avoided.
Disturbs the resin drainage flow and causes non-uniform wall thickness across the geometry

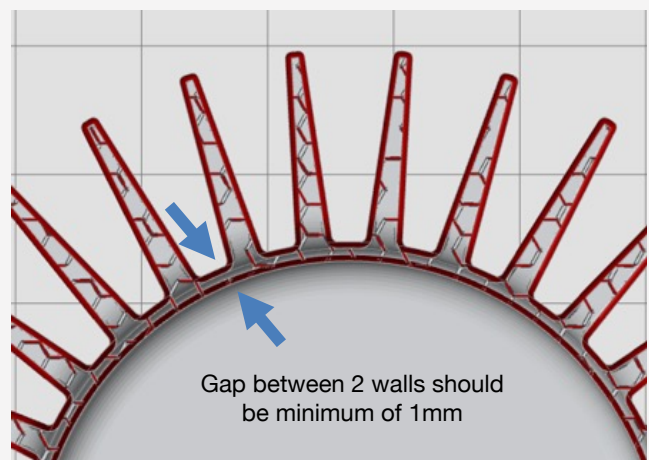

Example of an improved design



Design Guidelines

Infill

Photocentric Hexagon infill ([Download STL](#)) recommended to minimise cupping effect and maximises resin drainage

Photocentric Infill 3D Design Schematic

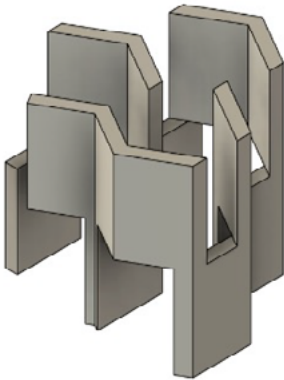

Infill Population Settings

Create Structures [X]

1. Outer Shell 2. Structure

Type [v]

- BCC+FCC
- BCC+FCC xy removed
- D sheet demo
- D solid demo
- fcc_neg-lattice
- G sheet demo
- G solid demo
- P sheet demo
- P solid demo
- Photocentric Investment Casting Infill FINAL v1

[Add] [Delete]

Dimensions [v]

X: 10.000 mm [v]

Y: 10.000 mm [v]

Z: 10.000 mm [v]

Keep aspect ratio

Options [v]

Strut radius: 0.500 mm [v]

Cross section: 4 [v]

Invert structure

Advance [v]

Spacing [v]

Spacing

dX: -2.000 mm [v]

dY: -0.500 mm [v]

dZ: 0.000 mm [v]

Start position [v]

Angled growth [v]

[Back] [Finish] [Cancel]

Cross-sectional view of infill structure after population

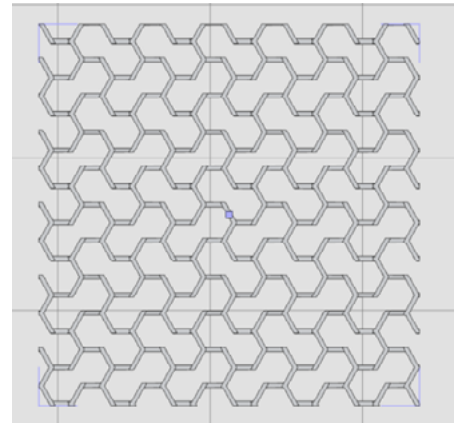



Design Guidelines

2. Adding Drain Holes

Main Geometry Drain Holes

6 mm in diameter;
For internal cavities, place drain holes through double walls to relieve cupping and minimise blowouts.



Placement tip 1: When printing a hollow part with a horizontal base, place drain holes on the side wall instead of the flat bottom surface to improve drainage and reduce print defects.

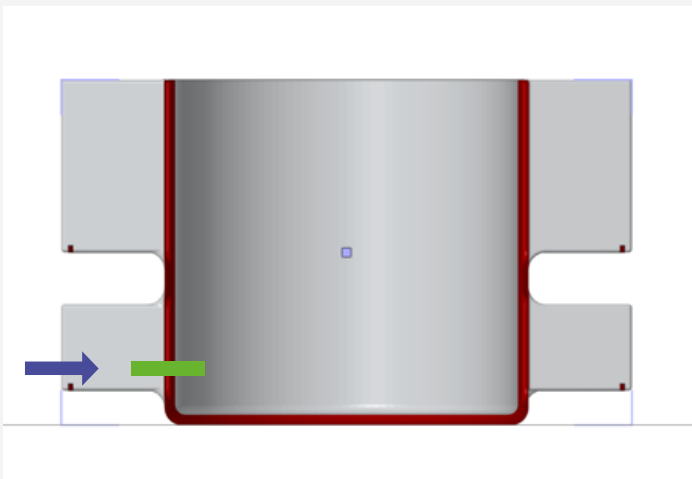

Incorrect placement

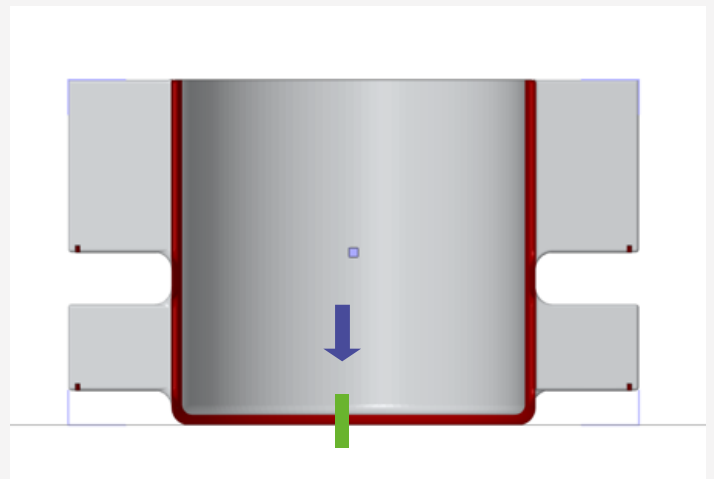

Correct placement



Design Guidelines

Placement tip 2: If the part is tilted at an angle, add drain holes in the lowest fins to allow resin to drain effectively after printing.

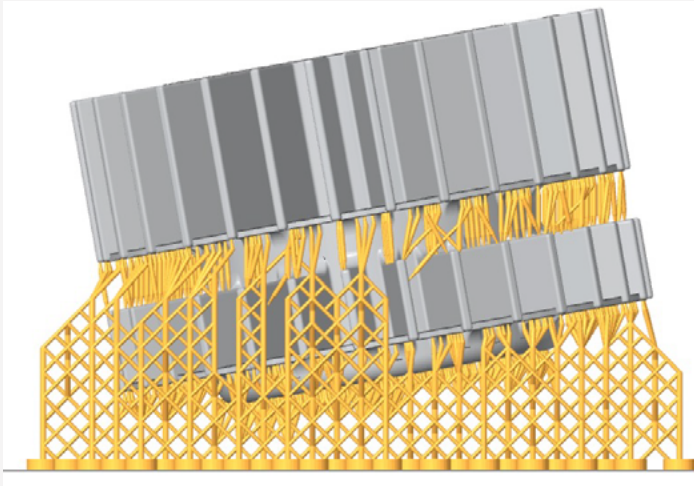

Geometry side view

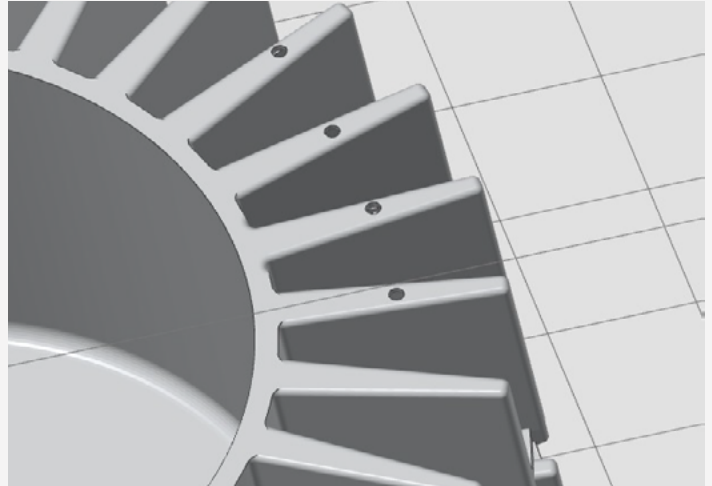

Bottom of the geometry, showing bottom drain holes

Placement Tip 3: For every enclosed cavities, ensure to add drain holes to prevent resin from becoming trapped. All trapped volumes must include at least one drain hole.

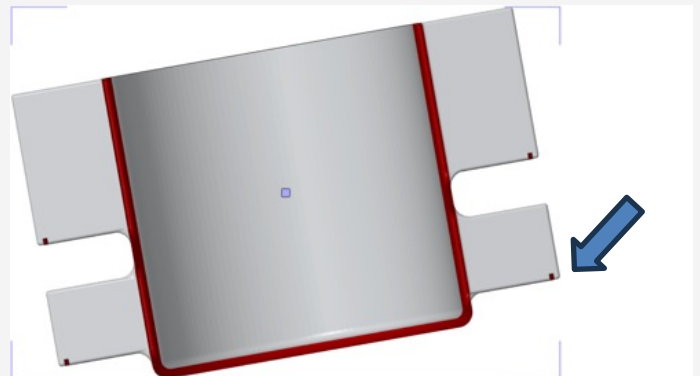

Double Wall Drain Holes

3 mm in diameter;
Should be added to one of the walls to allow uncured resin and cleaning solvent to drain after printing and cleaning.

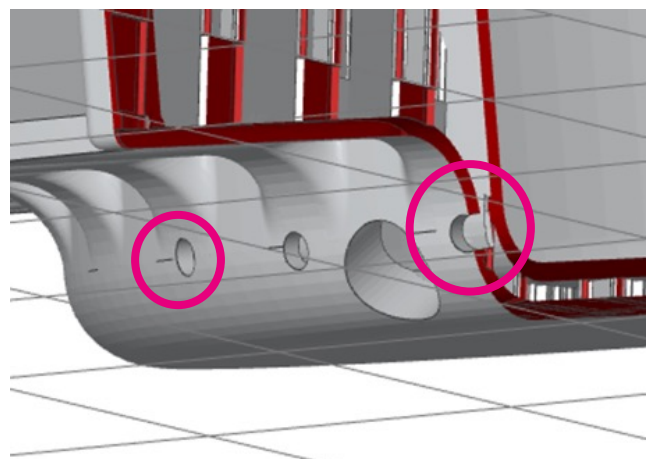



Design Guidelines

3. Orienting and Adding Supports

General principle	Always orient the part first, then add supports to stabilise overhangs.
Optimum orientation – gradual surface changes	For optimum orientation, ensure that surface area grows gradually from layer to layer. Sudden changes in the surface area can create visible lines or warpage during printing.

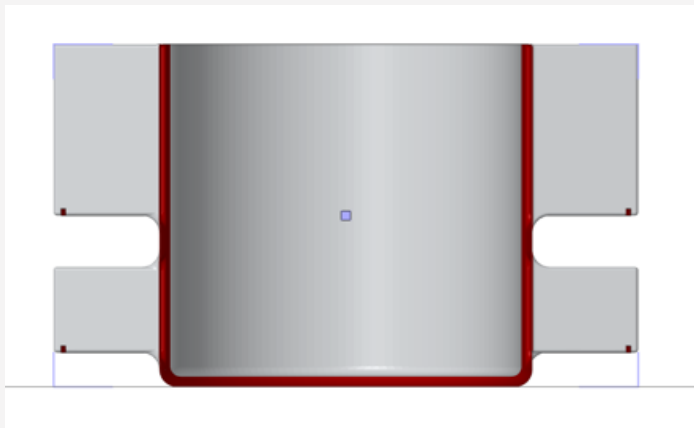

Non optimum orientation

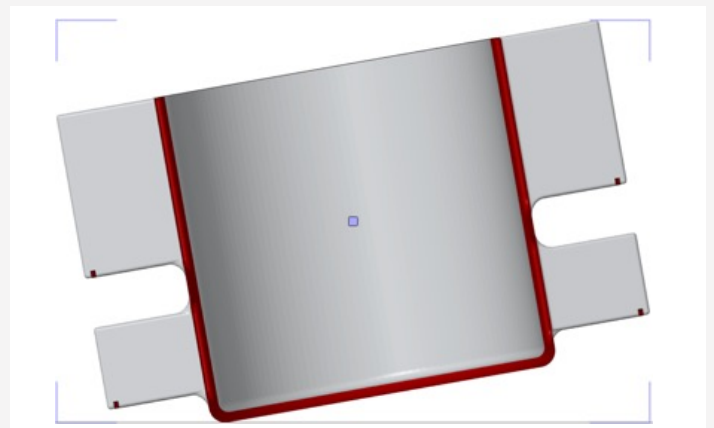

Good orientation

Surface quality	Orient parts to achieve smoother surfaces and minimise support scarring.
Adding supports strategy	Minimise and strategically place supports to reduce post-processing and protect the finish of critical surfaces.



Design Guidelines



Pre-Print Instructions

Printing on LC Magna

1. To print with Photocentric LC Magna, choose Cast DL60 - Black and the desired layer thickness when preparing your print file in Photocentric Studio.
2. Shake the resin bottle for 2 minutes before pouring into the LC Magna resin vat.

Printing on LC Titan

1. To print with LC Titan, choose Cast DL60 - Black and the desired layer thickness when preparing your print file in Photocentric Studio.
2. Shake the resin bottle for 2 minutes before pouring into the LC Titan resin tank.



Post-Print Instructions

Post-Processing on LC Magna

1. Place the platform into the Photocentric Air Wash L.
2. Parts can be washed for no more than 10 minutes using Photocentric Resin Cleaner 30.
3. Once washed, rinse with warm water for maximum of 10 minutes.
4. It is important for parts to dry fully, prior to post-curing. Dry with compressed air to remove any remaining water and allow the part to drain fully.
5. Place the platform into the Cure L2 set to 40 °C with no UV light. Allow the part to reach temperature, then hold for 1 hour for small parts or 3 hours for large parts.
6. Turn on the light and cure for minimum of 5 hours at 40°C with light on in Cure L2.
8. Remove the platform from the Cure L2, allow to cool down and remove parts from the platform.

Post-Processing on LC Titan

1. Place the platform into the Photocentric Wash XL.
2. Each part can be washed for 10 minutes using Photocentric Resin Cleaner 30.
3. Once washed, rinse with warm water for maximum of 10 minutes.
4. It is important for parts to dry fully, prior to post-curing. Dry with compressed air to remove any remaining water and allow the part to drain fully.
5. Place the platform into the Photocentric Cure XL, start 'Dry' cycle for 1 hour at 40°C (WITH NO UV LIGHT) to ensure parts are fully dry (we recommend 1 hour for small parts and 3 hours for large parts).
6. Start 'Cure' cycle, and leave to cure for minimum of 5 hours at 40°C.
7. Remove the platform from the Cure XL, allow to cool down and remove parts from the platform.



Design Guidelines



Casting Guidelines

Shell Casting- Preparation & Burnout

1. Remove the supports and polish the surfaces as required.
2. Seal drain holes in the foundry using wax. Verify the pattern is fully sealed by blowing air or smoke into one of the drain holes.
3. Apply 7–8 layers of ceramic slurry coats.
4. Add sufficient vent to prevent shell cracking.
5. Casting with aerospace aluminium alloy – Skip the autoclave step and follow the burnout cycle below.
6. Proceed with normal cool-down and casting steps.

Foundry Burnout Cycle - Shell Casting of Aerospace Aluminium

Target Temp (°C)	Ramp Rate (°C/min)	Ramp Time	Hold Time
RT → 200	30	5 minutes	–
200 → 300	5	20 minutes	–
300 → 400	2.2	45 minutes	–
400 → 465	0.8	1 hour 20 mins	–
465 → 800	1.1	6 hours	4 hours

Flask Casting- Preparation & Burnout

1. Remove the supports and polish the surfaces as required.
2. Seal drain holes in the foundry using wax. Verify the pattern is fully sealed by blowing air or smoke into one of the drain holes.
3. Continue with normal flask casting setup.
4. Casting with aerospace aluminium alloys –follow the burnout cycle below.
5. Proceed with normal cool-down and casting steps.

Foundry Burnout Cycle - Flask Casting of Aerospace Aluminium

Target Temp (°C)	Ramp Rate (°C/min)	Ramp Time	Hold Time
RT → 150	30	5 minutes	–
150 → 300	0.5	5 hours	–
300 → 700	3.3	2 hours	8 hours