

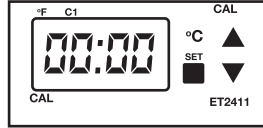

Power
on/off

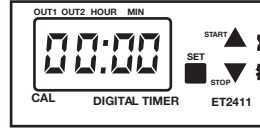

Temperature controller



Timer controller

USER MANUAL

THE NEXT GENERATION
OF 3D PRINTING IS HERE



Photocentric
CURE M+

Photocentric
CURE M+

EC DECLARATION OF CONFORMITY



PHOTOCENTRIC CURING UNIT
MODEL: CURE M+

Manufacturer
Photocentric Ltd
Cambridge House, Oxney Road
Peterborough, PE1 5YW, UK
Tel: +44 1733 349937
info@photocentric.co.uk
Year of CE Marking: 2021

Paul Holt
Director

Date of Issue: 5th January 2021

Place of Issue: Peterborough

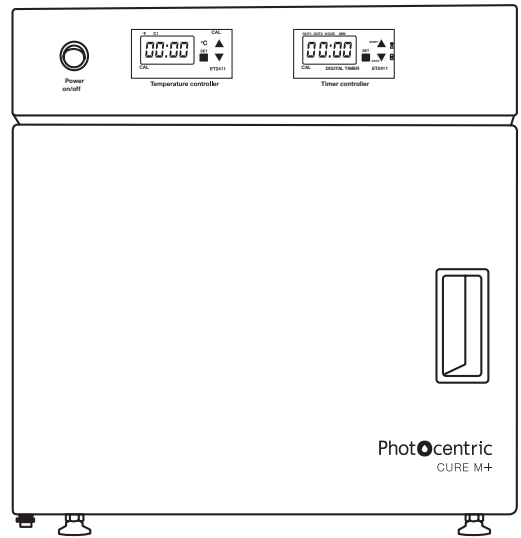



SAFETY INFORMATION

Please read the instructions carefully. Keep this document for future reference. Follow all warnings/instructions marked on the product.

- Cure M+ weighs 20 kg. Make sure you have 2 people to correctly remove the unit from the crate.
- The dimensions of Cure M+ are 390mm(H)x440mm(D)x440mm(W). Take care to choose a flat, stable work space to accommodate the dimensions.
- Plug in the power cord first and then attach to the AC power outlet. Or, vice versa, unplug the power cord before disconnecting from the printer.
- Do not operate outdoors without suitable protection
- Do not allow any resin to enter the chassis: clean spillages immediately.
- Disconnect the printer from AC outlet before storage or when not used for a long period of time or inactive for long periods of time.
- This unit is connected to the electrical network with an input of 110-240V, 50/60 Hz.
- Do not allow anything to rest on the power cord. Do not locate this product where people could walk on the cord or in a walk-through location.
- If an extension cord is used with this product, make sure that the total ampere rating of the equipment plugged into the extension cord does not exceed the extension cord ampere rating. Also, make sure that the total rating of all products plugged into the wall outlet does not exceed the fuse rating.
- Do not overload a power outlet, strip or receptacle by plugging in too many devices.
- Use the product only with the supplied power supply cord set.
- In case of malfunction, disconnect the printer immediately from the power network.
- Do not attempt to fix this product by yourself, as opening or removing covers may expose you to potentially dangerous voltage points to other risks.
- Refer all repairs to qualified service personnel. Please send an email to your national supplier or contact technical service at:
support@photocentric.co.uk

To unplug, first turn the power off by the mains and leave to discharge for 10-15 seconds. The plug and power cord can then be disconnected. Do not operate if one of the following has occurred:

- The power cord or plug is damaged, cut or frayed.
- Liquid has been spilt in the machine. Or, the unit exposed to any source of water. (including rain)
- The machine has been dropped or the case had been damaged
- The machine does not operate normally after following the operating instructions

SAFETY GUIDELINES

- Keep the unit, platform and un-cured parts out of the reach of children.
- The unit should be operated on a stable and level surface, preferably away from direct ambient light.
- Do not look directly into the light if they are on (This should not be possible with the safety switch). If you have them please wear light blocking goggles.

DISPOSAL INSTRUCTIONS

Do not throw any electronic device into typical house hold waste when discarding. To minimise pollution and to help protect the environment, please recycle this unit or return to Photocentric.

Please note that the latest instructions can always be found on our website:

www.photocentricgroup.com/3d-support

PHOTOCENTRIC M+

USER MANUAL



Power
ON/OFF



Temperature controller

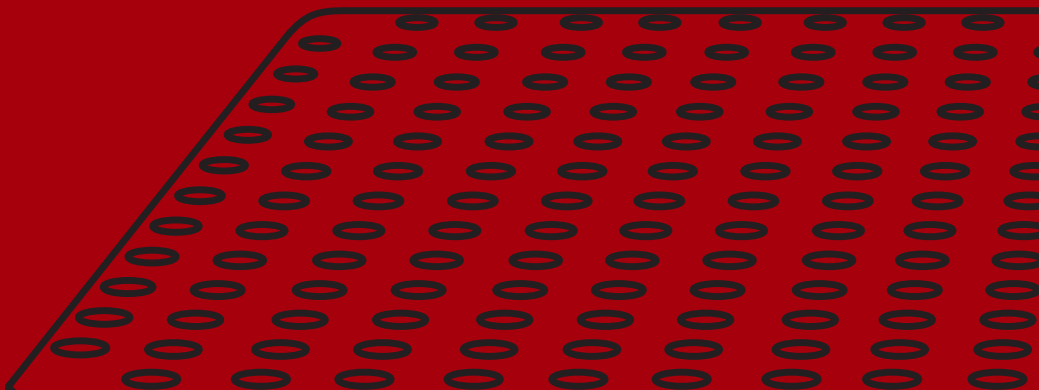

It is important that you read, understand and comply with these original instructions prior to using the equipment and safely store this document for future reference.

Contents

1. Description of the essential parts of the machine	7
2. Safety rules	8
3. Safety devices	8
4. Environmental protection	8
5. Intended use	8
6. Before operating Cure M+	9
7. Starting and stopping your Cure M+	9
8. Essential maintenance and care of your Cure M+	10
9. Troubleshooting	10
10. Technical specifications	10
11. Warranty	10

let's get to
know it...

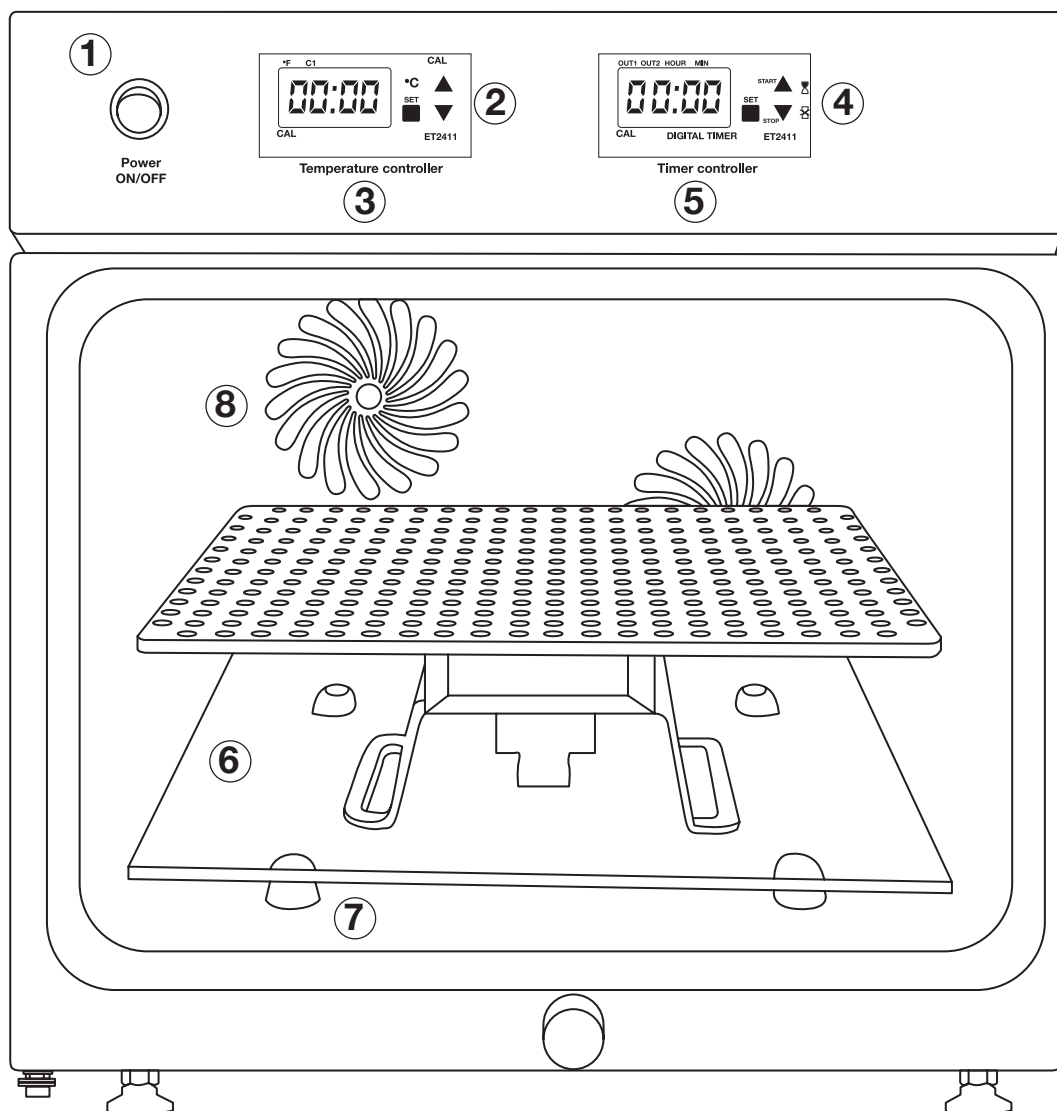

- | | |
|--------------------------|-------------------|
| 1 On/Off Switch | 6 Glass platform |
| 2 Temperature adjustment | 7 Platform stands |
| 3 Temperature Display | 8 Internal vents |
| 4 Time adjustment | 9 UV Light |
| 5 Time display | |

1- SYMBOLS USED IN THIS USER MANUAL



Danger:

Immediate danger that may cause severe injury or even death to persons.



Warning:

Possible hazardous situation that could lead to severe injury to persons or property.



Caution:

Possible hazardous situation that could lead to mild injury to persons or damage to property.



Recycle:

Always recycle old damaged or redundant parts or packaging materials.

2- SAFETY RULES



Warning:

Under no circumstances must the machine be operated with the door open.



Warning:

Do not touch the interior of the machine with bare hands immediately after a full curing cycle has been completed.

3- SAFETY DEVICES



Danger:

Never circumvent the door safety switch as the LED unit will cause severe damage to vision.

4- ENVIRONMENTAL PROTECTION



Recycle:

Most of the packaging material can be recycled. Please do not throw the packaging material into a domestic household waste system, send it for recycling.



Recycle:

Old machines contain valuable materials that can be re-used or recycled: please send your old machines to a suitable recycling centre at the end of its lifespan.

5- INTENDED USE

This machine is intended to Cure 3D-printed parts only inside its enclosure. This machine is not intended to work outdoors without suitable protection.



Recycle:

Remove the outer packaging and recycle it.



Caution:

Possible hazardous situation that could lead to mild injury to persons or damage to property. This machine is 20 kg (44.1 lbs), make sure to follow correct lifting procedures when handling.

When the machine is positioned correctly, locate the mains plug lead and plug it into the socket on the rear of the machine. Push and plug in and twist clockwise to engage the power.

6- BEFORE OPERATING CURE M+

This unit may only be connected to an electrical supply which has been installed in accordance with all relevant IEC regulations.

This unit has also been developed to work on any power supply from 220—240 VAC. Do not connect this machine to the mains supply without an isolating switch.

Always check main cables for damage prior to use. Only authorised persons may replace damaged cables to this machine.

7- STARTING AND STOPPING YOUR CURE M+

Starting

On the front of the machine press the green rocker switch and the unit will light up and switch on.

Loading:

Open the door and place the platform (with parts attached) onto the glass plate (6). Make sure that the platform is placed evenly on the stands. This will prevent any damage to the platform or the parts.

The machine will not be operated if the door is open.

To start the UV curing program, press the 'Set' button on the temperature/time control (2 & 4 on Figure 1); then using the arrows, set the desired temperature or time. Once the desired temperature and/or time are selected, hold the set button until there is a change to the colon display shown (Hour:Minute). The unit will then start the UV curing program.

Temperature settings:

The unit temperature is factory set to a standard of 62°C (also the maximum temp). You can use a lower temperature by pressing the 'Set' button on the unit once, then pressing the down button you can set your machine to the desired working temp. Depending on the country and voltage of your machine, the heat-up time will vary between 5-15 minutes. For accurate and precise curing you will need to wait until the temperature has reached the selected setting before loading the prints in to the unit.

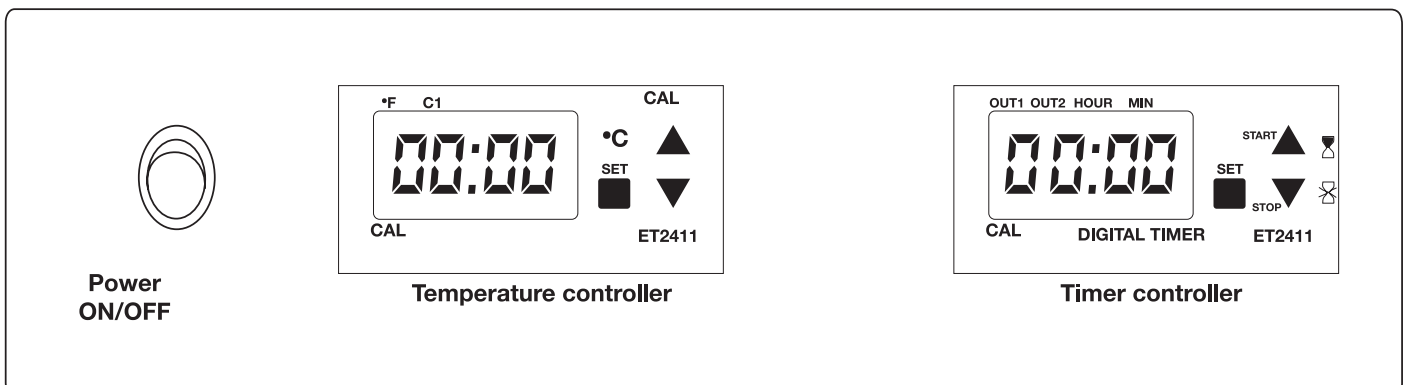

Figure 1: Temperature and Time controls.

Unloading:

Open the door and, using suitable heat resistant gloves, remove the glass plate and close the door as soon as possible. This maintains the Cure M+ Temperature.

If you are not going to place another printer part into the unit straight away, you can leave the door. You must leave the free rocker switch on to allow heating elements to cool down.

8-ESSENTIAL MAINTENANCE AND CARE OF YOUR CURE M+



Danger:

Risk of injury; electrical shock.

DAILY CHECKS

Ensure that the inside of the machine is kept clean, especially the glass covering the UV lights.

Check the condition of the door seal the main cables.

Make sure the vents on the top of the of the unit are not overly dusty or covered.

Check the vents are working correctly before heavy use.

9- TROUBLESHOOTING



Danger:

Risk of injury, electrical shock. Always disconnect the mains power supply before commencing ANY maintenance on this machine. Any electrical problems should be checked by a qualified engineer.

Machine fails to start.

Does the green switch light come on?

If not, confirm that you have a working power supply. To do this check the fuse in the plug. If the fuse is not the problem then contact a qualified engineer.

Machine has power but the heater fails to work, or the light fails to come on.

Check the fuse on the left hand side of the machine (rated to an 8 A current). If the fuse is not the problem then contact a qualified engineer.

10- TECHNICAL SPECIFICATIONS

Photocentric Cure M+

Height of the machine	(390 mm or 15.4")
Width of the machine	(440 mm or 17.3")
Depth of the machine	(440 mm or 17.3")
Weight of the machine	(20 kg or 44.1 lbs)
Power Supply	220-240 VAC)
Power consumption	(4-9 A)
Noise	(<40 Db)

Control devices

Control switches	(24 VDC)
Transformer	(24 VDC ± 3%)

The unit delivery packaging also contains:

- 1 x Photocentric Cure M+
- 1 x Power Cable (with external charger)

11- WARRANTY

We offer 12 months “parts only” manufacturer’s warranty on all mechanical parts. All parts under warranty are to be returned to Photocentric for assessment prior to refunds.

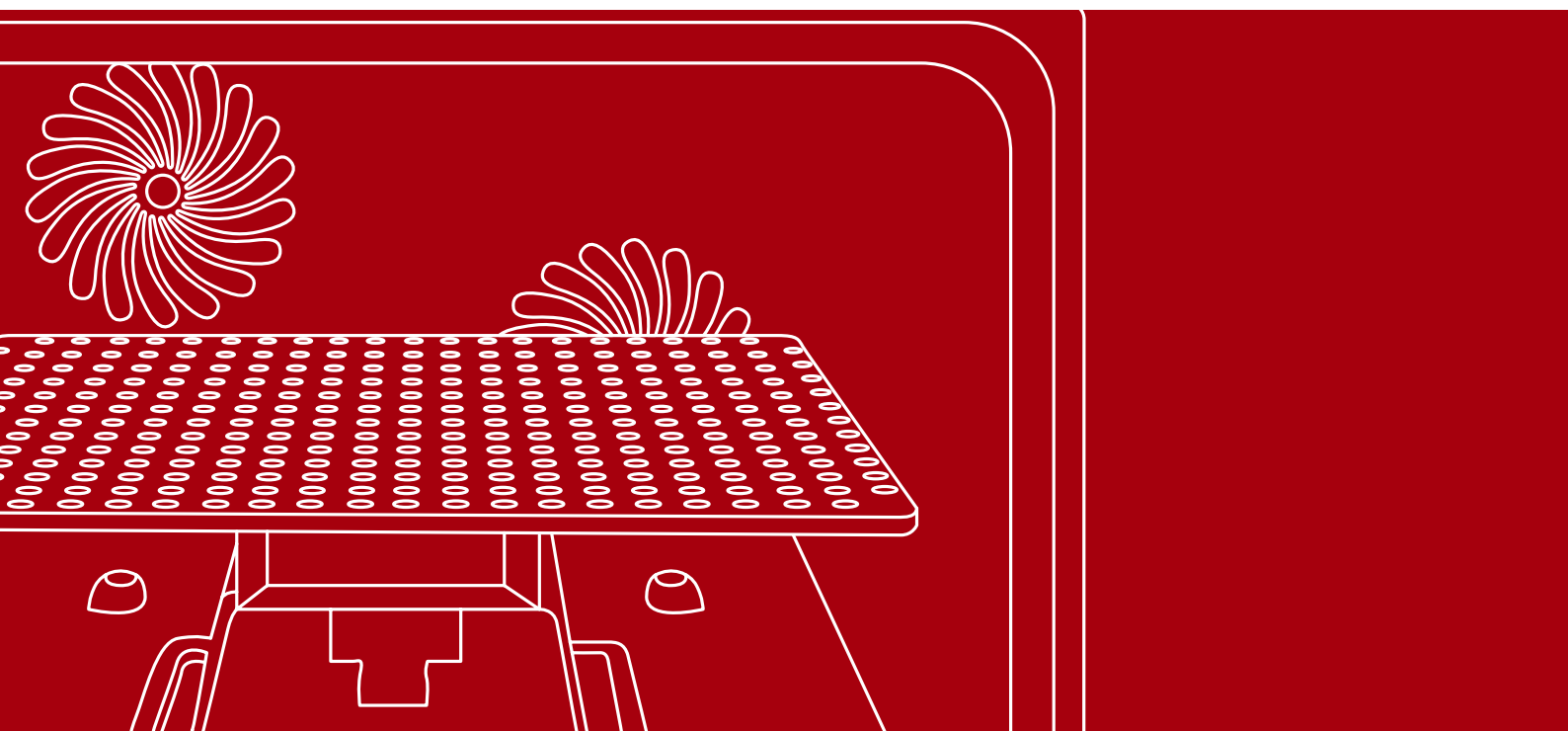

DISPOSAL INSTRUCTIONS

Do not throw this electronic device into the waste when discarding. To minimize pollution and ensure utmost protection of the global environment, please recycle or return to Photocentric for recycling.

UK

Cambridge House, Oxney Road
Peterborough PE1 5YW UK.
info@photocentric.co.uk
www.photocentricgroup.com

USA

2205 West Parkside Lane, Phoenix,
85027, AZ USA
www.photocentricgroup.us