

# THE NEXT GENERATION OF 3D PRINTING IS HERE

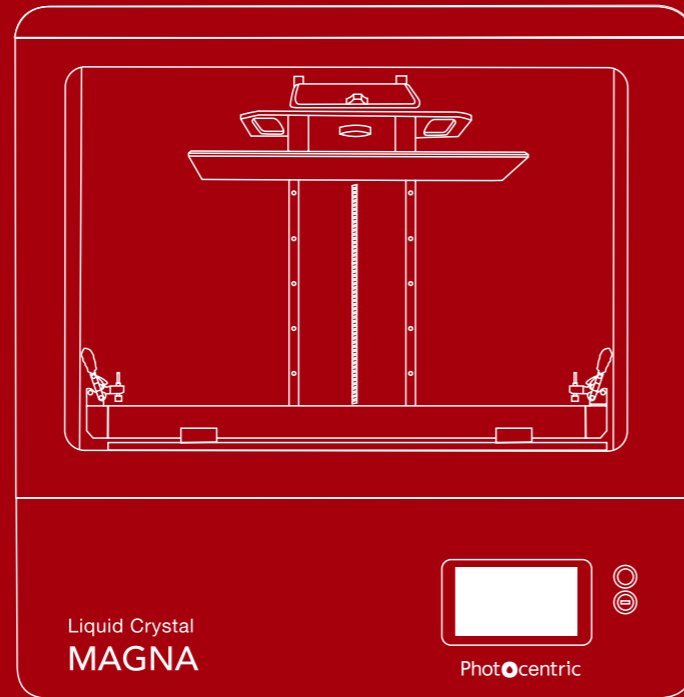

# LC MAGNA USER MANUAL

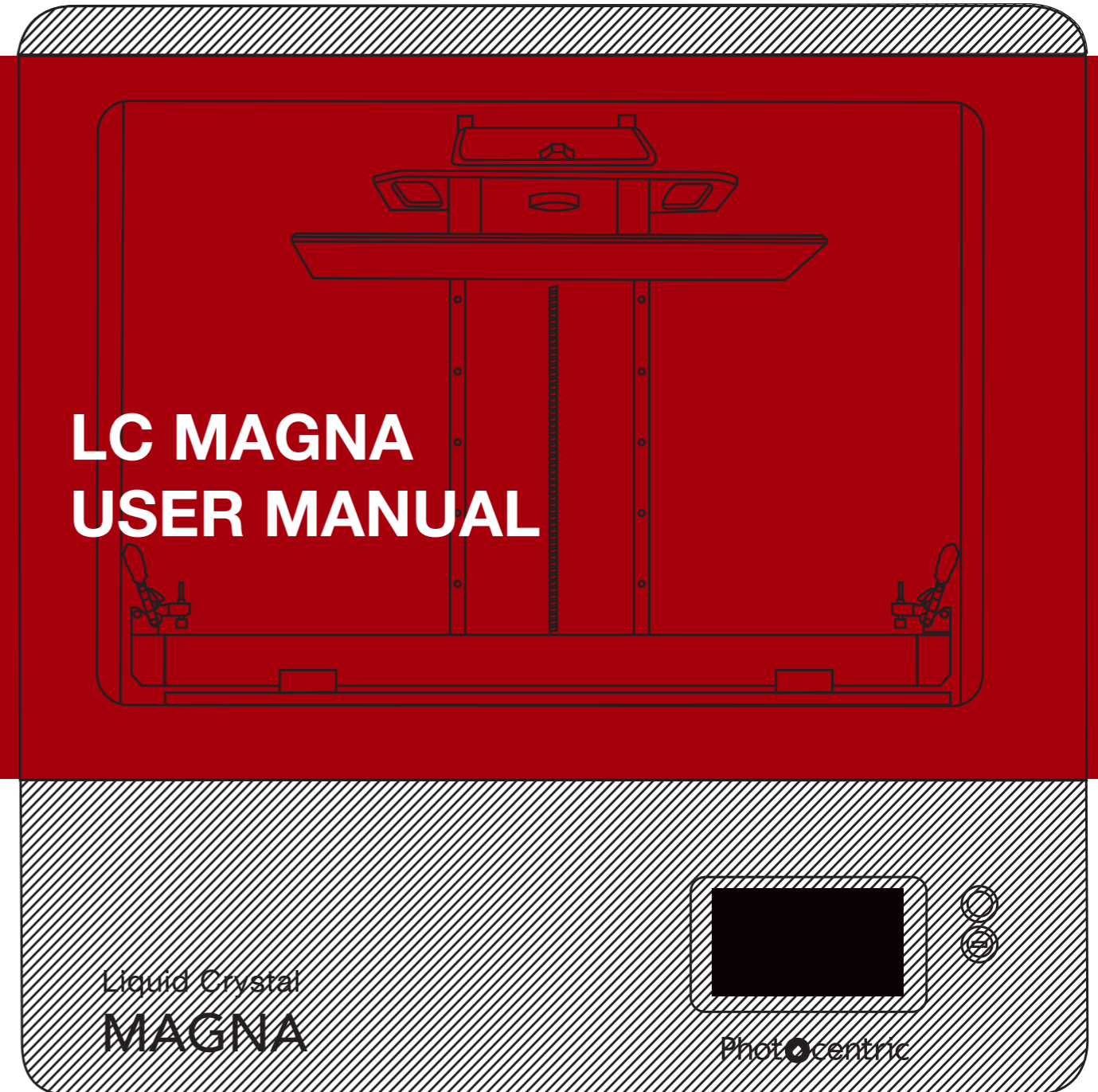

#### DISPOSAL INSTRUCTIONS

Do not throw this electronic device into the waste when discarding. To minimize pollution and ensure utmost protection of the global environment, please recycle or return to Photocentric for recycling.

Photo**centric**

**UK**  
Titan House, 20 Titan Drive  
Peterborough, PE1 5XN  
info@photocentric.co.uk  
www.photocentricgroup.com

**USA**  
Avondale 107 - Building 'A' 855 N. 107th Ave., Suite  
A110, Avondale, Arizona 85353  
www.photocentricgroup.us



Liquid Crystal

**MAGNA**

## Contents

<b>1. EU Declaration of Conformity</b>	<b>1</b>
<b>2. General Information</b>	<b>2</b>
<b>3. Safety Information</b>	<b>3</b>
<b>4. Box Contents</b>	<b>4-5</b>
<b>5. Installation</b>	<b>5</b>
<b>5.1. First Look at LC Magna</b>	<b>5-6</b>
<b>5.2. Printer Setup</b>	<b>7</b>
<b>5.3. GUI Introduction</b>	<b>7-9</b>
<b>5.4. Photocentric Studio Setup</b>	<b>9</b>
<b>5.5. Connecting to a Network</b>	<b>9-10</b>
<b>5.6. File Transfer</b>	<b>10-12</b>
<b>6. Printing</b>	<b>13-15</b>
<b>7. Cleaning Prints</b>	<b>15-16</b>
<b>8. Finishing Prints</b>	<b>17-18</b>
<b>9. Housekeeping</b>	<b>18-19</b>
<b>9.1. Removing Resin from the Vat</b>	<b>18</b>
<b>9.2. Maintaining Print Platform</b>	<b>18</b>
<b>10. Maintenance</b>	<b>19</b>
<b>10.1. Replacing the Resin Vat Film</b>	<b>19</b>
<b>10.2. Print Platform Re-Calibration</b>	<b>20</b>
<b>10.3. General Maintenance</b>	<b>21</b>
<b>11. Useful Links &amp; Resources</b>	<b>22</b>

# 1. EU DECLARATION OF CONFORMITY

## LIQUID CRYSTAL 3D-PRINTER

Model: Liquid Crystal Magna

We hereby declare that the product above is compliant with the essential requirements of the following:  
Machinery (MD), 2006/42/EC. Electromagnetic Compatibility Directive (EMC), 2004/108/EC, 2014/30/EU.  
Restriction of the use of certain hazardous substances (RoHS) Directive, 2011/65/EU Commission  
Regulation (EU) No. 453/2010 and IEC 60950-1 Safety of ITE.

Technical Documentation is stored at the manufacturer's address below

**Signed for and on behalf of:** Photocentric Ltd

**Place of issue:** Peterborough  
**Date of issue:** 17th June 2019  
**Name:** Paul Holt  
**Position:** Director  
**Signature:**



Manufacturer  
Photocentric Ltd  
Cambridge House, Oxney Road Peterborough  
PE1 5YW, UK  
Year of CE Marking: 2019

# 2. GENERAL INFORMATION

Liquid Crystal Magna is an innovative 3D printer, designed and manufactured in the UK by Photocentric Ltd. This printer uses visible light to cure photo-polymer resin and build objects layer by layer. Equipped with a powerful patented peel-release system, 'Blow-Peel' to enable reliable large surface area printing and custom UK designed LED arrays for maximum accuracy and speed. Liquid Crystal Magna has been designed with several industry applications in mind. As 3D printing becomes more integral to optimized production, Liquid Crystal Magna is a powerful addition that will assist with boosting productivity and will quickly become an established unit in any context.

**MANUFACTURER**  
PHOTOCENTRIC

**MODEL**  
LC MAGNA/  
LC MAGNA V.2

**BUILD SIZE**  
510 x 280 x 350 mm

**SOFTWARE**  
Photonic 3D V1.7



**FILE STORAGE**  
25GB CAPACITY

**RESOLUTION**  
3840 x 2160px

**BACKLIGHT**  
460nm

**PIXEL PITCH**  
137 MICROMETER

For further information, please visit our website: <https://photocentricgroup.com>

On our website you can find:

- Software downloads
- Comprehensive instructional videos
- Fully updated user manuals
- An online shop, for consumables, ancillary equipment, and spares
- Contact details for our customer support team

## 3. SAFETY INFORMATION



This information must be read through carefully for Liquid Crystal Magna User Safety. Retain this information for any future reference.

- Take note of all warnings displayed on the 3D printer.
- Follow all instructions displayed on the 3D printer packaging and the machine.
- Liquid Crystal Magna weighs 110 kg. Photocentric recommends using a forklift truck or pallet lifting machine to handle the printer. If necessary to move Liquid Crystal Magna manually, four people will be required. Please refer to the LC Magna Installation Guide [here](#).
- Operate the 3D printer on a flat and stable surface that can safely support the weight.
- Position the 3D printer at a height that allows a comfortable posture during operation.
- Keep the 3D printer and photopolymer resin out of the reach of children.
- Liquid Crystal Magna requires a mains power supply with a voltage 110-240VAC and a frequency of 50-60Hz.
- The main power consumption is 1300W. It will draw a maximum of 7A when connected to 240VAC, or 13.5A when connected to a 110VAC.
- Only connect Liquid Crystal Magna to the mains socket using the power cable supplied.
- Liquid Crystal Magna is recommended to be used with a Ground-Fault Circuit Interrupter (GFCI).
- Ensure that the total current draw of all items connected to the mains circuit does not exceed the capacity of the fuse or circuit breaker.
- Always plug the power cable into the mains socket and the 3D printer before switching on the power at the mains socket.
- Always switch off the power at the mains socket before unplugging the power cable from either the 3D printer or the mains socket.
- Do not place anything on top of, or resting against, the power cable.
- Do not position the power cable that it causes a trip hazard or is likely to be stepped on.
- Disconnect the 3D printer from the mains socket when not in use.

- Do not operate Liquid Crystal Magna outdoors.
- Liquid Crystal Magna should not be operated in direct light from the sun or any UV light source.
- Liquid Crystal Magna should be operated in an ambient temperature of 20°C - 25°C. Operating temperature should not exceed 40°C.
- It is highly recommended Liquid Crystal Magna should be operated in a well-ventilated room. Information on extraction can be found on [LC Magna Installation Guide](#).
- Do not operate Liquid Crystal Magna with the door open as you may be exposed to crush hazards.
- Photopolymer resin is an irritant. Always wear gloves and safety glasses when handling.
- Do not operate Liquid Crystal Magna if you display signs of sensitivity after exposure to photopolymer resin, such as skin or eye irritation.
- Do not allow photopolymer resin or any other liquid to get inside the casing of the 3D printer. Clean up any spills immediately.
- In case of malfunction, switch off the power at the mains socket and disconnect the 3D printer immediately.
- Do not disassemble Liquid Crystal Magna as you may be exposed to electric shock hazards, harmful UV light or other hazards.
- All repairs should be carried out either by or with the assistance of Trained Personnel.
- Discontinue 3D printer operation and contact your supplier if:
  - o The power cable or plug is damaged.
  - o Liquid is inside the casing of the 3D printer.
  - o The 3D printer has been dropped.
  - o The 3D printer shows signs of damage.
  - o The 3D printer does not operate correctly after following the instructions provided in this user manual.
- Dispose of waste photopolymer resin according to the SDS of the material. Do not dispose of this through typical plumbing systems.
- Dispose of Liquid Crystal Magna responsibly. Please recycle where possible or return to Photocentric for recycling.

## 4. BOX CONTENTS

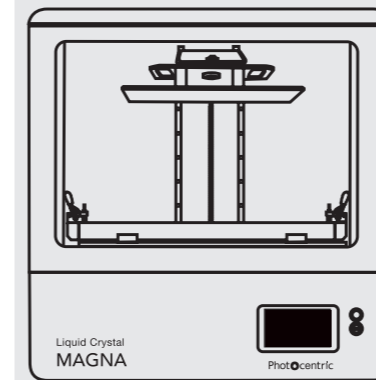

Liquid Crystal Magna

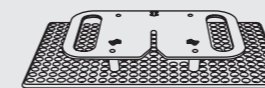

Print Platform (Factory Calibrated)

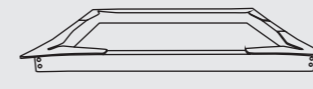

LC Magna Resin Vat

### RECOMMENDED ADDITIONAL ITEMS

Safety Glasses  
 Spray Bottle  
 Paper Towel  
 Cleaning Solvent  
 (e.g. Isopropyl Alcohol)  
 Resin \*  
 Photocentric Airwash L \*  
 LC Magna Vat Film Pack \*  
 LC Magna Resin Vat \*  
 LC Magna Print Platform \*  
 LC Magna Slotted Platform \*

\* Available from Photocentric

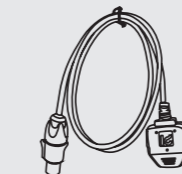

1) Power Cord



2) 32GB USB



3) Wi-Fi Dongle

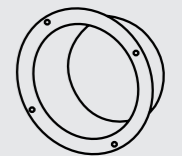

4) Extraction Spigot 100mm

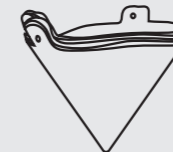

5) 5x Paper resin filters



6) Funnel



7) 2x Pairs of Gloves



8) Vat Cleaning Tool



9) Soft Spatula



10) Scraper



11) Pozi1 Screwdriver



12) Pozi2 Screwdriver



13) 2x Vat Gaskets



14) 1 x Blow Peel Gasket

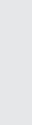

15) 12x Foam Tip Swap

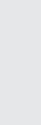

16) 4x Pipette

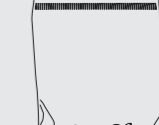

20x Small Vat Screws



20x Large Vat Screws



2x Vat film

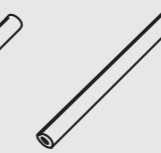

Vat Cleaning Foam Mat

### 4.1 CONTENTS DESCRIPTION

#### Electrical & Network Connectivity

1. Power Cord- to connect LC Magna to the mains power socket.
2. 32GB USB Flash Drive- to manually transfer .cws or .zip files to LC Magna. It also contains the following:
  - a. Photocentric Studio License
  - b. Resin Safety Data Sheet
  - c. CE Certificate
  - d. Liquid Crystal Magna Instructions
3. Wi-Fi Dongle- to connect LC Magna to your secure local wireless internet network.

#### Extraction

4. Extraction Spigot Ø 100mm- to connect LC Magna to extraction unit.

#### Housekeeping & Part Removal

5. Paper Filter (x5) - to filter solid debris or cured resin while pouring into container.
6. Funnel - to support paper filter while pouring resin back into its container after print job completion when emptying the LC Magna resin vat.
7. Gloves - to prevent skin contact when handling the resin and cleaning solvent.
8. Vat Cleaning Tool- To guide and collect residual resin from the vat into the container. Can also be used to re-disperse pigments in the resin if the printer has remained idle for a prolonged period.
9. Soft Spatula- to remove small bits of cured resin from vat film while cleaning or carefully from the screen after a minor vat leak.

# Liquid Crystal MAGNA

10. Scraper- To remove printed parts from LC Magna platform and to assist with cleaning of the print platform and resin vat.

## Vat Re-Skinning

11. Pozi 1 Screwdriver- to remove small screws when changing the vat film.
12. Pozi 2 Screwdriver- to remove large screws when changing the vat film.
13. Vat gasket (x2)- to replace the foam gasket between vat ring assembly and vat walls when changing the vat film.

14. Blow-Peel Gasket (x1)- To create a seal between the vat and the screen protector to ensure the Blow-Peel is inflating effectively.

15. Foam Tip Swab- To clean vat leak sensors.
16. Pipette (x4)- To flush/clean vat leak sensors.

## 5. INSTALLATION

### 5.1 First Look at LC Magna

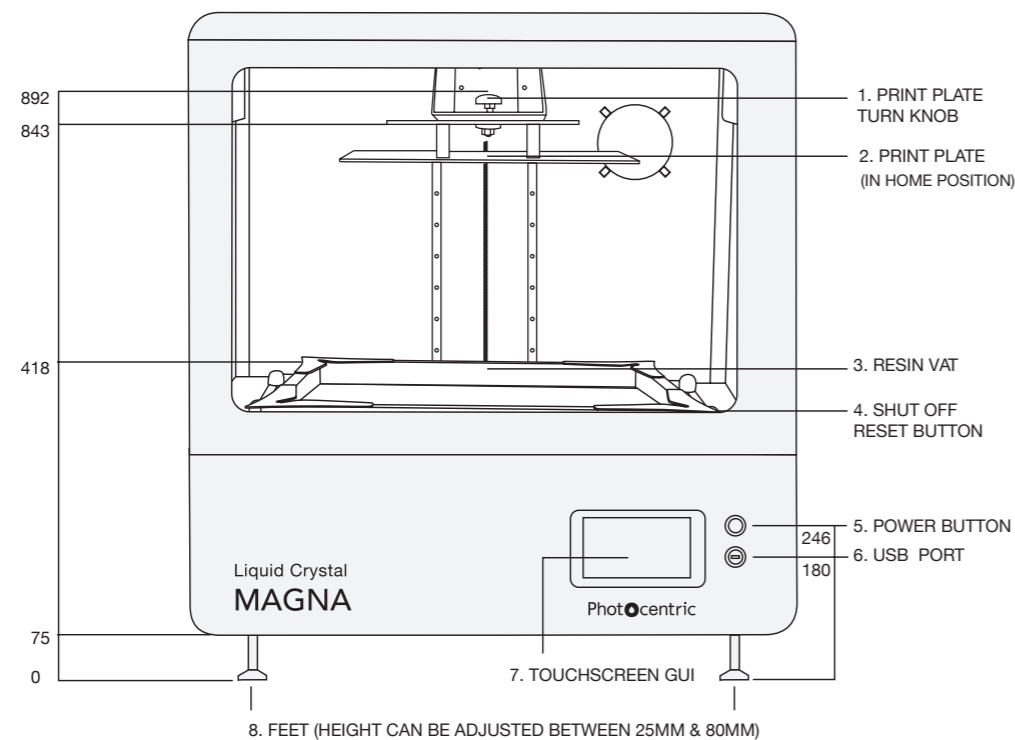

Figure 1: Liquid Crystal Magna front view

1. Print Platform Turn Knob- used to secure the print platform prior to printing or to remove it upon print completion.
2. Print Platform (in home position)- an Aluminium assembly with the following features:
  - a. A coating for easier cleaning and removing excess resin.
  - b. Roughened print platform silver surface to increase first layer adhesion.
  - c. The print platform has been pre-calibrated

on our production line according to strict QC procedures. This ensures that the bottom surface of the print platform is parallel with the LCD screen.

d. Interchangeable platforms, print platforms can be swapped between printers without the need for re-calibration or homing. To achieve optimum Z accuracy, it is recommended that 2 or more new platforms are dedicated to one printer and swapped between each other.

# Liquid Crystal MAGNA

3. Resin Vat- Contains the resin required to complete print jobs, featuring:

- a. Spouts to ease the process of pouring resin back into its container.
- b. Volume gauge which indicates the amount of resin inside the vat.
- c. Durable optically clear film to ensure accurate prints and increased longevity.

4. Printer LCD Screen- Underneath the resin vat is a 24" LCD screen which displays the slices within the .cws or .zip file, curing the layer of resin between the vat film and the print platform. The screen is covered by a clear screen protector.

5. Shut Off/Reset Button- If a resin leakage occurs, it may enter one or more of the vat leak sensors. The sensors prevent resin from damaging the

'Blow-Peel' system by shutting off the valve(s) and alerting the user by an alarm. For further explanation of the cleaning procedure after a vat leak, please follow the link to the support video on the Magna Resource Hub.

6. Power Button- to turn LC Magna ON and OFF, can be used to power the printer or in case of an emergency.
7. USB Port- to transfer sliced files via the USB Flash Drive provided or, any non-password protected USB to LC Magna.
8. Touch Screen GUI- This interactive GUI allows users to control, connect and maintain LC Magna by following simple steps.
9. Door Switch & Interlock- Safety feature to abort the movement of the print arm if the interlock is disengaged during printing.

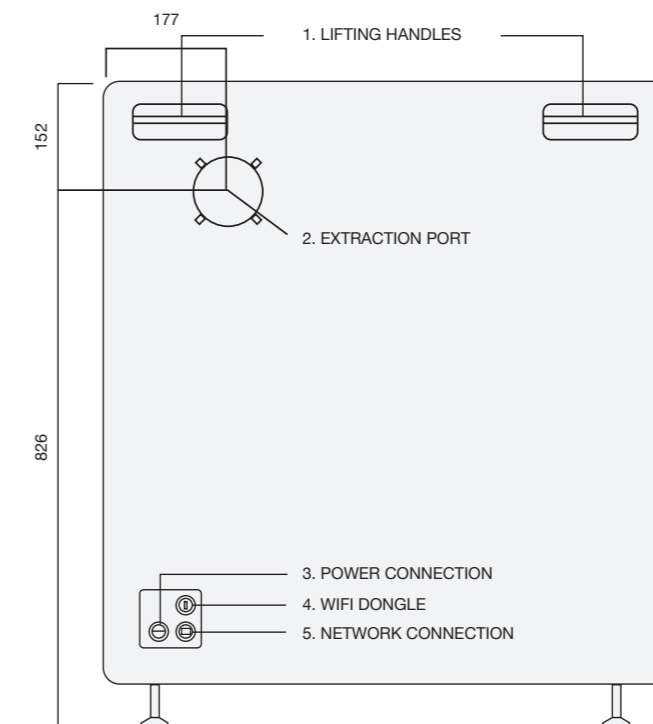

Figure 2: Liquid Crystal Magna - rear view

1. Lifting Handles- when moving LC Magna to a new location, the lifting handles can be used. Please refer to the LC Magna Installation Guide for further guidance.
2. Extraction Port- to connect LC Magna to an external extraction unit if required. Please refer to the [LC Magna Installation Guide](#) for further guidance.
3. Power Connection- this socket has been carefully selected to ensure a secure and reliable power inlet.

4. USB Port for Wi-Fi Dongle- to plug in the provided Wi-Fi Dongle to enhance LC Magna's Wi-Fi detection and connection to a secure local wireless network.
5. RJ45/Ethernet Network Connection- LC Magna can be securely connected to a LAN or RJ45 network.

## 5.2 PRINTER SET-UP

By now and following Liquid Crystal Magna (LC Magna) Installation Guide, the printer should have been located in a suitable place and is now ready to be set up.

The printer power socket is on the back of the machine at the right-hand side. Only connect LC Magna to the mains using the power cable provided. Always plug the power cable into the mains socket, then into the printer before switching on using the power button at the front (as shown below). Similarly, always switch off the power at the front before unplugging the power cable from either the printer or the mains.

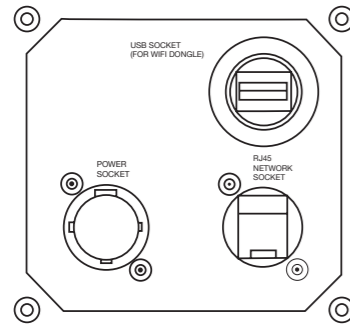

Once LC Magna has been connected to power, the foam blocks protecting the screen during shipping need to be removed before printing.

1. Close the printer door.
2. Select 'Maintain' from the Main Page on the GUI.
3. Select 'Lift Platform' and wait for the printer arm to reach its homing location.
4. Once the movement is complete, open the printer door and remove the foam blocks.
5. Remove the GUI screen protector.
6. The printer is now ready to use.

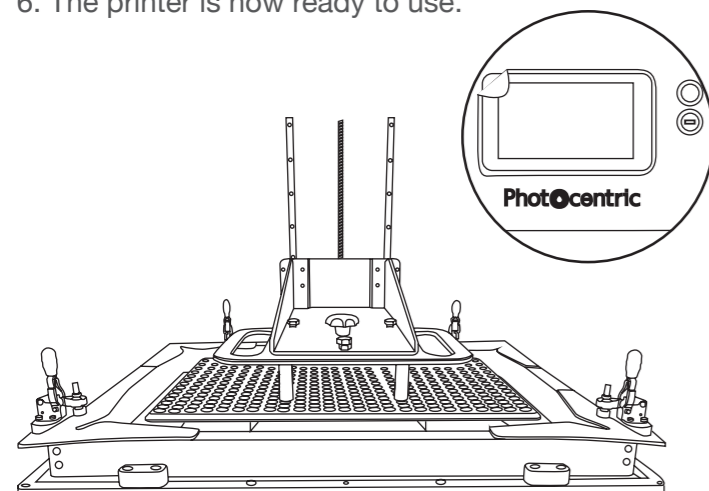

## 5.3 GUI INTRODUCTION

Liquid Crystal Magna GUI is the main control for users to print, control, maintain and connect the printer to a network.

### Main Page

The 'Main' page is the initial display when the printer is switched on and provides access to different menus.

In all other menus, the option to return to the 'Main' page will be available.

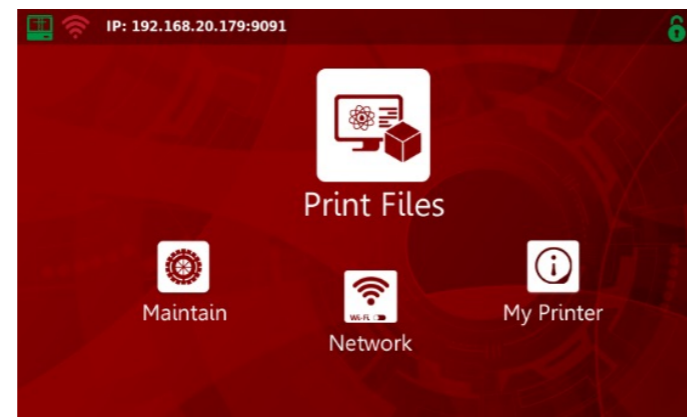

**IP: 192.168.20.121:** Printer IP Address appears when the printer is connected to a network. If the IP Address is not displayed, the printer is not connected to a network

	To navigate through to loaded files and initiate a print
	To check and maintain printer features
	To connect LC Magna to a Wi-Fi Network
	Overview of Printer Capacity

	<ul style="list-style-type: none"> <li>Printer System is not ready</li> <li>Printer System is launching</li> <li>Printer System is up and running</li> </ul>
--	--

	<ul style="list-style-type: none"> <li>No Wi-Fi Connection</li> <li>Strong Wi-Fi connection</li> <li>Good Wi-Fi Connection</li> <li>Weak Wi-Fi Connection</li> <li>Poor Wi-Fi Connection</li> </ul>
	<p>The door switch safety feature provides safe printing operation for LC Magna. If the printer door is open, prints will not start, nor will the linear drive move.</p> <ul style="list-style-type: none"> <li>Printer door is open</li> <li>Printer door is closed</li> </ul>
	<p>Interlock in Magna compliments the door switch function to avoid opening the door during mechanical movements.</p> <ul style="list-style-type: none"> <li>Interlock is disengaged</li> <li>Interlock is engaged</li> </ul>

### Print Files Page

This page displays the files stored on the printer either by online or offline transfer that are available to print.



	Function enables prints to be arranged alphabetically or by chronological upload order.
<b>File(s) list</b>	List of stored files available to print. Scroll up and down to see more. It is recommended that files are deleted after use to best utilise printer memory and retain processing memory for faster performance of the GUI.

	Refresh button for file transfer so that files are visible on the list.
	Once selected, highlighted files can be deleted from the printer's memory.

### Maintain Page

The 'Maintain' page offers functions that check and maintain printer features. It is recommended that these features are used by or with the support of trained personnel.

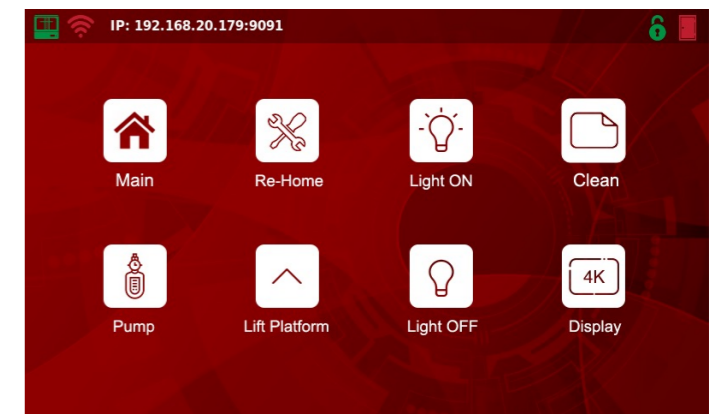

### NOTE:

When selecting the 'Maintain Page' button, the LC Magna logo on the front panel will turn from red to blue.

	Navigate back to "Main page"
	LC Magna print platforms are factory calibrated in accordance with strict QC procedures prior to shipping. Please contact your supplier for information on re-homing should the need arise.
	The 'Light On' function will confirm that LC Magna's light engine is working properly. The light engine will illuminate behind the screen for 10 seconds.
	Cures a full layer of resin to assist with cleaning the resin vat.



Pump

LC Magna works with patented peel release technology called Blow-Peel. We suggest testing the functionality of this feature weekly and immediately after a vat leak in accordance with maintenance schedule (Section 10). During this procedure, air will be pumped between the screen and vat film, causing the vat film to inflate. The vat film should remain inflated until the pump starts vacuuming the air out.



Lift Platform

To lift the print platform to its homing location.



Light OFF

Once you select 'Light On', you can turn it off by pressing 'Light Off'. Or, light will go off automatically after 10 seconds.



Display

To check the printer screen function, select 'Test LCD'. Photocentric logo will be displayed in the centre of the screen.

## 5.4 PHOTOCENTRIC STUDIO SET-UP

A 32GB USB flash drive is supplied with your LC Magna. On this drive you can find a license number for Photocentric Studio. This allows you to activate a perpetual license for up to two PCs. Photocentric Studio can be downloaded from this [webpage](#)

### NOTE:

Photocentric recommends saving the license file locally on your PC in case the USB provided is misplaced or damaged.

On this page, you can also find guidance on the following:

- The minimum system requirements for Photocentric Studio
- Installing the software
- Getting started
- Adding supports and slicing files
- Updating the software

To prepare files for printing, please follow the below steps:

1. Upon opening Photocentric Studio, select LC Magna/LC Magna V.2/LC Magna V.2 Fast Printing\* from the machine profile drop down menu. Then, select the desired resin profile from the material drop down menu, click 'Apply' for the software to load.

\* LC Magna V.2 Fast Printing machine profile only works for specific applications and resin. For more information, visit the Magna V.2 Fast Printing section on the Magna resource hub.

2. Import the desired file to Photocentric Studio and support as necessary. Please refer to the Photocentric Studio Support software videos for further guidance by following the link [here](#).

3. Once satisfied, record the resin volume required to print from the tool panel for use when setting up the print.

4. Slice the file and save to a specified location on your PC.

5. Upload the file to LC Magna via USB or web transfer.

### NOTE:

See Section 5.5 for further guidance on network connection.

## Network Page

LC Magna can be connected to a network to facilitate the uploading and removal of print files and to monitor prints in progress remotely.

## 5.5 CONNECTING TO A NETWORK

Once your Liquid Crystal Magna is switched on, plug in the ethernet cable or Wi-Fi dongle to establish a network connection. This allows print file uploads and remote monitoring. These instructions are a guide to setting up the connection and uploading a print file.

### 5.5.1 Connecting to a Network via Ethernet

Switch on LC Magna using the power switch at the front. Plug an ethernet cable into the designated socket at the back of the printer. Once the ethernet cable is connected, the IP address will be displayed in the top left corner of the Main GUI page.

### 5.5.2 Connecting to a Network via Wi-Fi

1. Plug in the Wi-Fi dongle to the USB port at the back of the printer.
2. On the 'Main' screen, select 'Network'.



3. Select the desired network from the list.

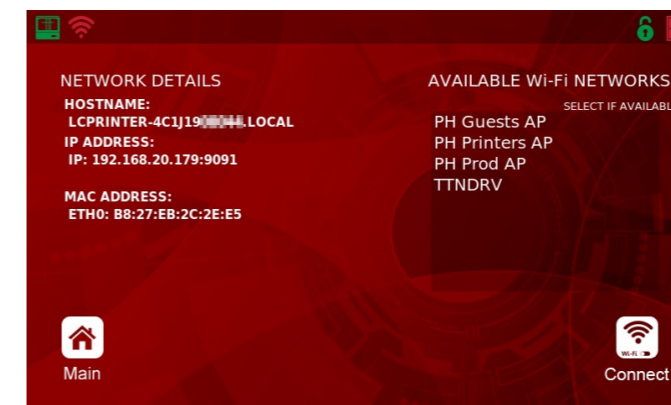

4. Select 'Connect'.

5. Select 'Password'.

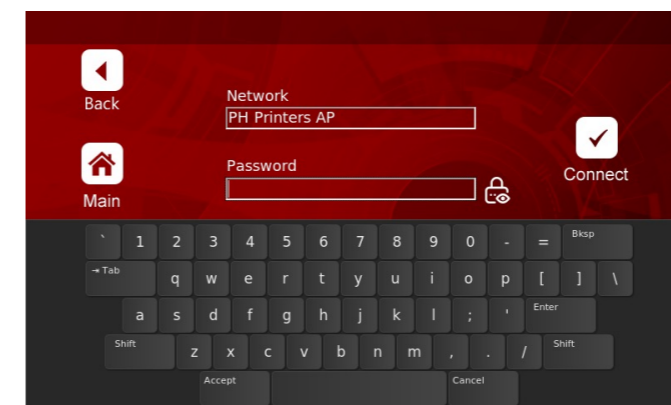

6. Enter the password for this network by using the on-screen keyboard. Password characters can be displayed by selecting the lock icon to the right of the text frame.

7. Select 'Connect' and wait for the connection to be established.

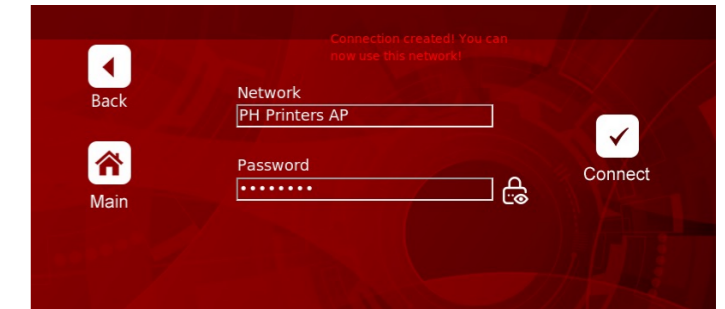

8. Select 'Main'.

9. The Wi-Fi icon at the top left of the main page should now be green. The IP address should be displayed next to it.

## 5.6 FILE TRANSFER

### 5.6.1 Online File Transfer

1. Connect to a Network. (See Section 5.5 for further guidance).
2. Open a web browser on your PC.
3. Type the printers' IP address into the search bar.

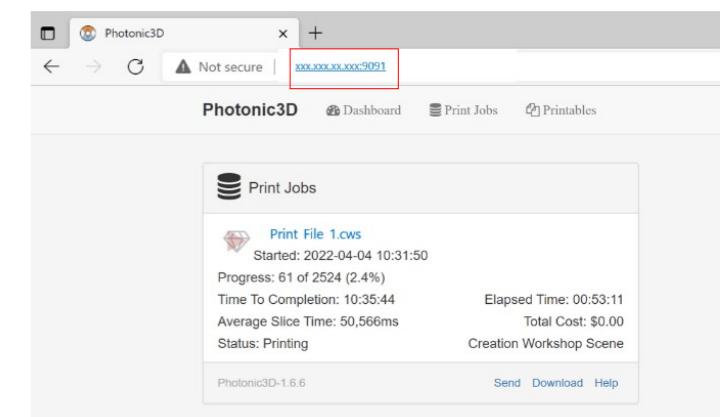

4. Select 'Printables' from the tabs at the top of the screen.

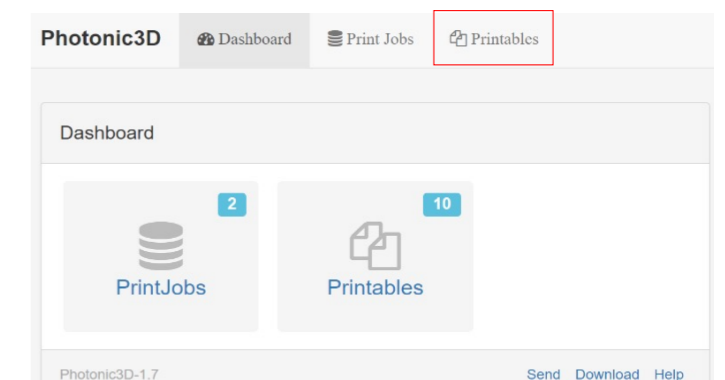

5. Select 'Upload'.



6. Select 'Choose File' and locate the print file on your PC, the name of the file will appear to the right of the 'Choose File' button.

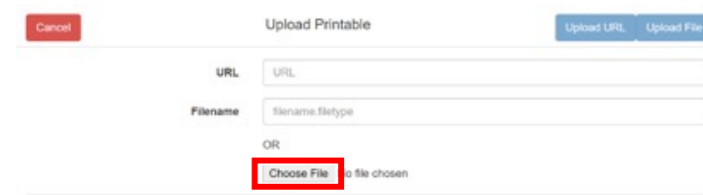

7. Select 'Upload File' and a progress bar will appear

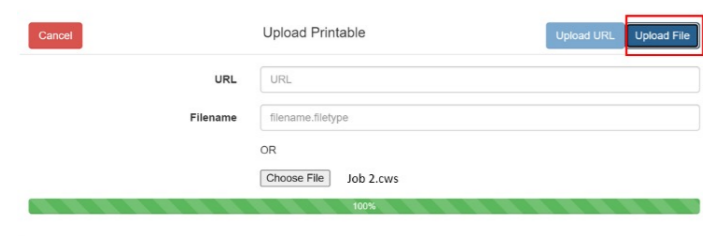

8. Once complete, the 'Printables' list will be updated to include the new file.

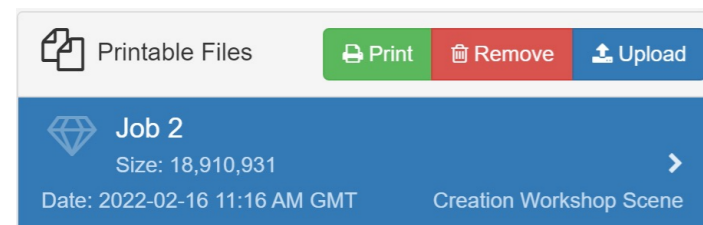

9. Select on LC Magna touch screen, go to 'Main' screen and select 'Print Files'.



The progress of prints can be monitored in the 'Print Jobs' section of the webpage.

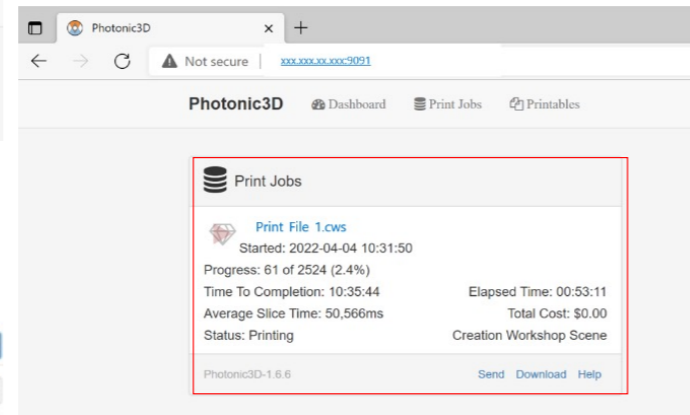

Monitor print progress here.

To delete files, go to the 'Printables' tab at the top of the page. Then, click on the relevant file and click 'Remove'.

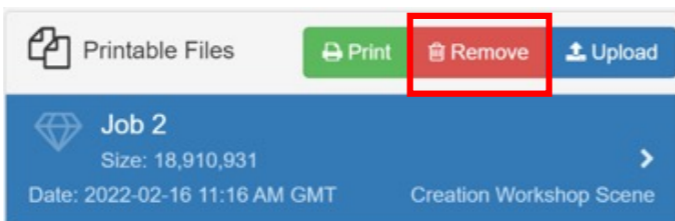

### 5.6.2 Online File Transfer

1. To transfer a print file to LC Magna, copy it to a USB flash drive, insert the USB drive into the USB port on the front of the LC Magna.

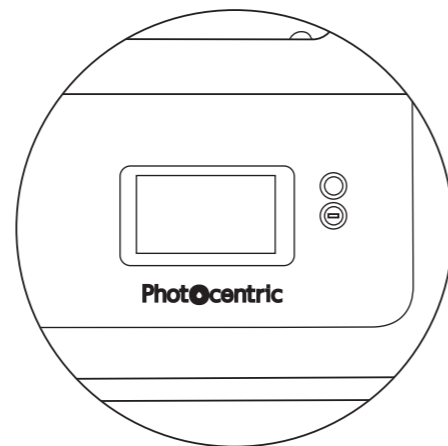

2. Select 'Print Files' from the 'Main' page.

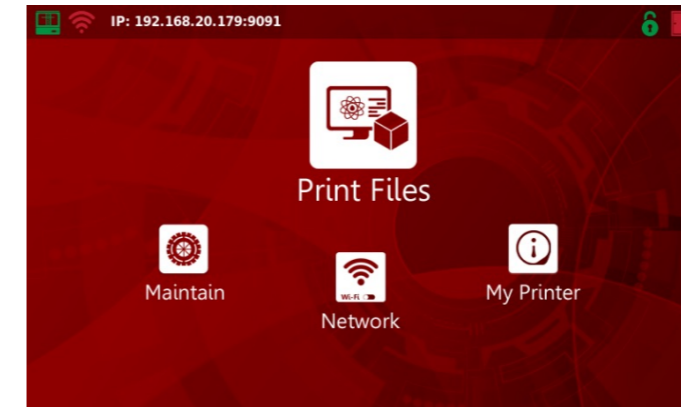

3. Select 'Refresh', the new print file should appear after a few seconds.



### 5.6.3 HTTP Upload to Machine

1. Once the file has been prepared and sliced on Photocentric Studio, it can be uploaded to the printer from within the software if the printer has an established network connection.

2. Select 'HTTP Upload to Machine' from the 'Slice' menu on the toolbar.

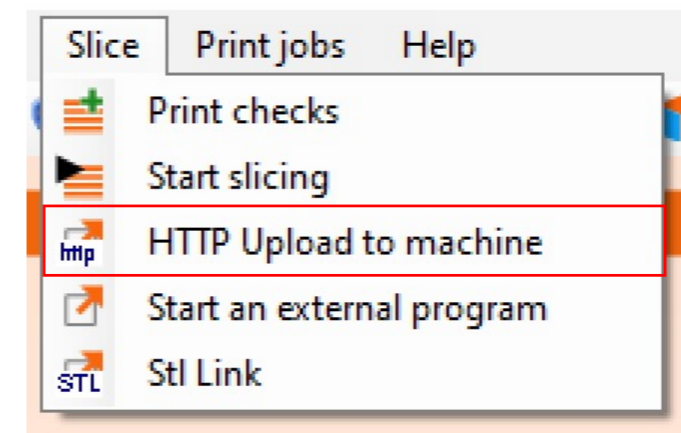

3. Input the IP Address of the printer in the following format: `http://xxx.xxx.xx.xxx:9091/services/printables/uploadPrintableFile/`

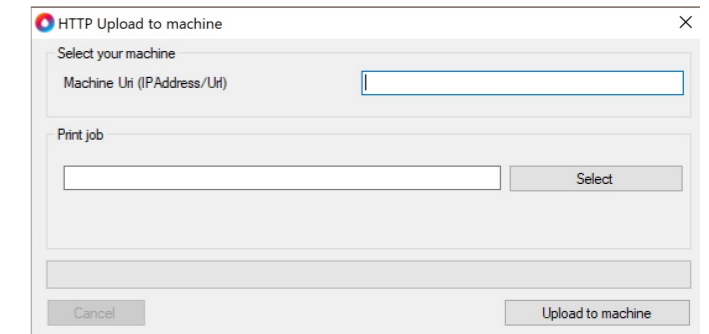

4. Click 'Select' to source the sliced file from its saved location, then click 'Upload to Machine'.

5. Press 'Refresh' on the Print Files page of the printer to show the uploaded file.

6. The print file and progress can be accessed online by typing the IP address into the search bar of your browser.

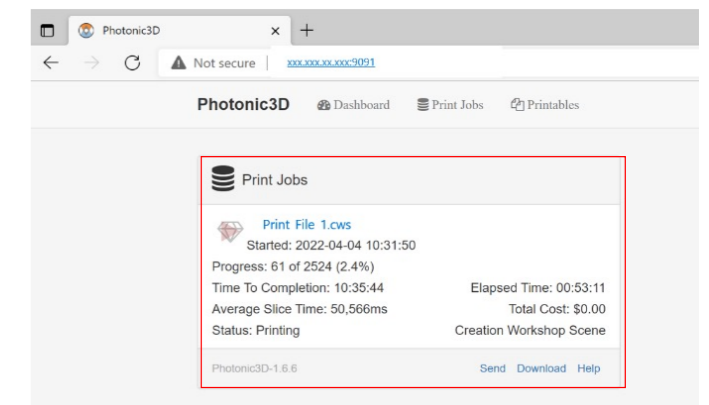



## 6. PRINTING

### 6.1 CHECKING ANCILLARY EQUIPMENT

Before printing, it is important to ensure that the LCD screen protector, print platform, resin vat & Blow-Peel are in good condition and properly installed. Failure to do so may result in damage to the vat film or a failed print. The steps outlined below have been summarised in the 'Setting up your first print' video on the Magna Resource Hub.

#### NOTE:

For each of the following steps, Photocentric recommends using gloves and wearing a lab coat and safety goggles.

1. Ensure that your Liquid Crystal Magna is positioned on a stable, level surface where it will not be subject to movement or vibrations during the printing process.
2. Ensure that the print platform is completely clean and dry, failure to do so may result in damage to your vat film or a failed print.
3. Load the print platform onto the print arm and tighten fully by turning the knob in a clockwise direction. Apply pressure on either side to ensure it is fixed in place.
4. Ensure that the resin vat is completely clean and dry to avoid print failures or damage.
5. Check the vat film for signs of damage or wear, if you have any doubt about the condition of the vat film, refer to Section 10.1.

#### WARNING:

If resin or debris enters one or more of the 4 resin detection sensors, a continuous, beeping noise will sound. Instructions to clean the LCD screen protector and resin leak sensors can be found in the Troubleshooting section of the [Magna Resource Hub](#).

6. Ensure the Blow-Peel Gasket is in place flush on the screen and not obscuring the Blow-Peel holes.
7. Place the vat flush onto the Blow-Peel gasket, then clamp the 4x vat clamps onto the vat secure the vat using the four vat clamps.
8. On the Maintain screen, go to the "Pump" feature. Follow the on-screen instructions and ensure the Blow-Peel is working effectively.

### 6.2 PREPARING RESIN FOR PRINTING

Before printing, it is important to heat the correctly selected resin to a sufficient temperature to improve printing quality. Shaking the resin before it's poured into the vat ensures pigments and other constituents of the resin are evenly dispersed.

1. Pick the selected resin bottle and loosen the cap to allow air to enter the bottle. Heat the resin in accordance with the resin TDS.
2. Once suitably heated, tighten the cap of the bottle and shake the resin in the container for 2 minutes.
3. Add the required resin volume reported on Photocentric Studio in addition to the 1.5l minimum level of the resin vat.
4. After the resin has been added and the vat and the print platform are in place, close the door of the printer. The icon at the top right corner of the GUI should show a green closed door when the switch is engaged.

#### NOTE:

Correctly selected resin is based on the resin profile selected in Photocentric Studio. If correct resin is not used, the print will fail.

5. On the 'Main' screen, select 'Print Files'



6. Select the desired file and press 'Print'.



#### WARNING:

Do not open the printer door during the printing process.

7. Your Liquid Crystal Magna will start the printing process.
8. During the print, the touchscreen will display various information including:

- Time Elapsed
- Time Remaining
- Total Time
- Print Progress Bar & Image

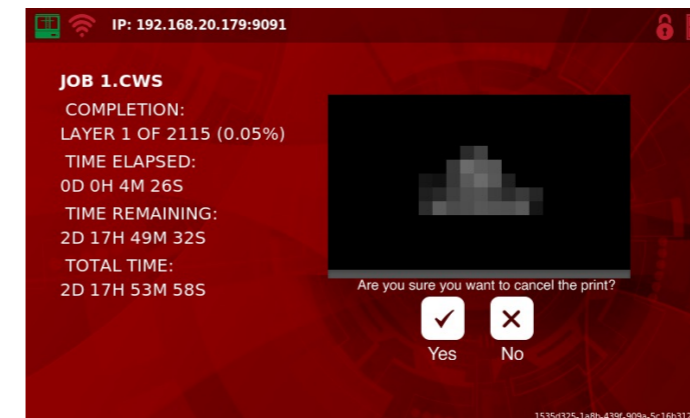

#### NOTE:

If your printer is connected to your network (see Section 5.5), you can monitor print progress via your web browser.

At any time during the printing process, you can pause or cancel the print by making the relevant selection.

### Pausing Prints

#### NOTE:

Do not pause the print unless absolutely necessary. If needed, only pause for a short time to avoid discrepancies in printing and ensure both the resin vat and print platform are not removed during this time.

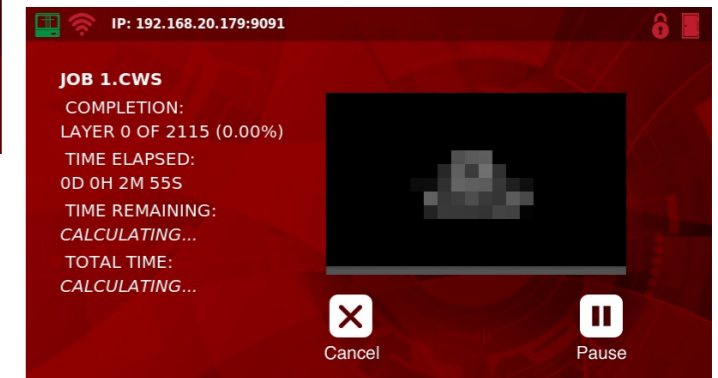

Select 'Pause' from the GUI.

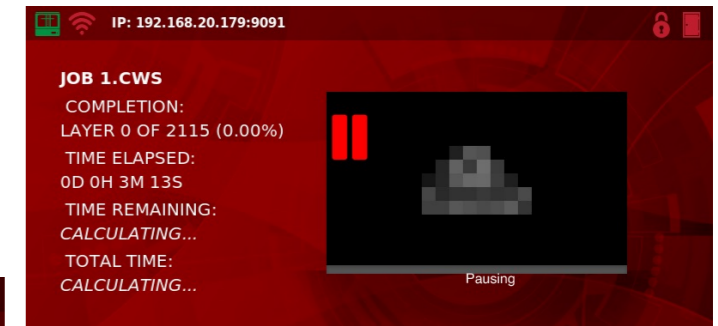

#### NOTE:

Once the cancel/resume options are displayed, the door can be opened. If opened sooner, the door and interlock could be damaged, and the print will be aborted with no option to resume.

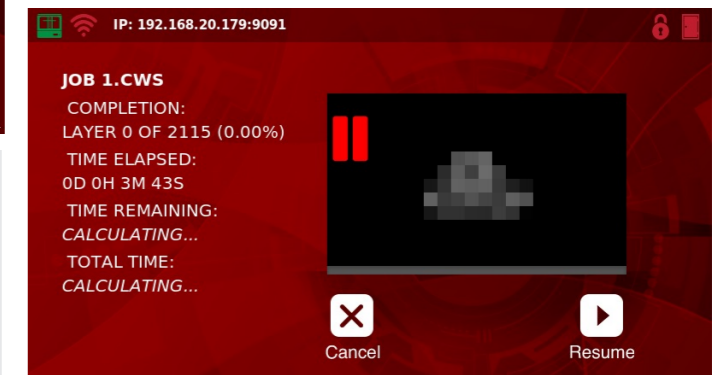

Wait for the layer to finish exposing. Once paused, the option will be given to cancel or resume the print.

## Cancelling Prints

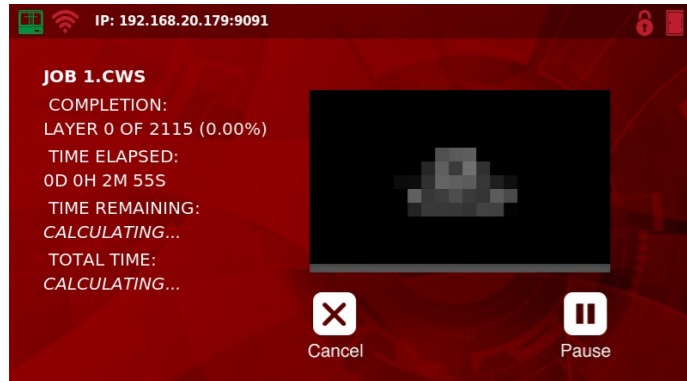

Select 'Cancel' from the GUI.

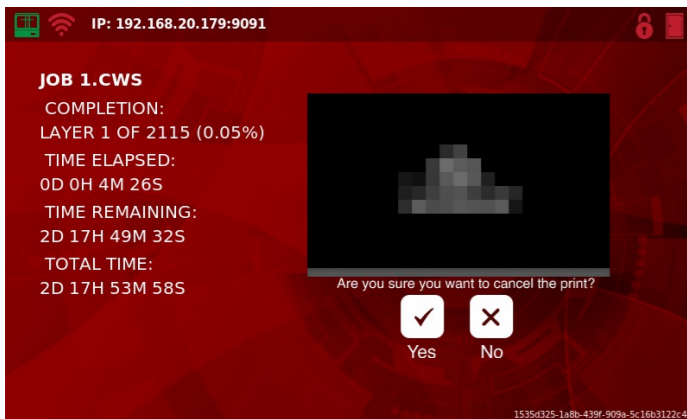

Confirm your choice by selecting the green tick.

- Once the current layer is complete, the print will stop, and the print arm will return to its homing location. Wait for all movement to cease before opening the door of the printer.

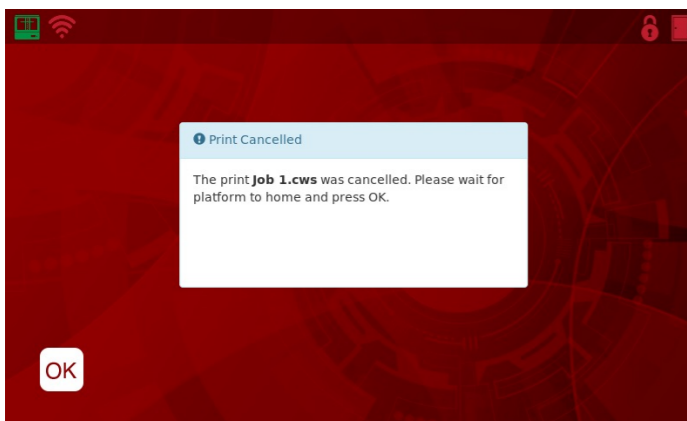

9. Liquid Crystal Magna does not need monitoring or supervision during the printing process, you do not need to be present when the print is due to finish.

10. Leaving a finished print inside the printer for a time will allow excess resin to drip back into the vat.

11. When you are ready to clean the print, open the door. Refer to Section 7 for further guidance on cleaning prints.

## 7. CLEANING PRINTS

To remove residual resin from printed parts and platforms, they will need to be cleaned. Photocentric recommends using the Photocentric Air Wash L.



### Air Wash L

External dimensions are:  
620 (L) x 400 (W) x 990.5 (D) mm.

Capacity 90l (20 gallons)

Photocentric Air Wash L can be purchased from this [webpage](#).

The user manual for Air Wash L can be downloaded from this [webpage](#).

Here you can find guidance on installation, cleaning and emptying saturated resin cleaner, and overall operation.

1. Free the platform by turning the knob in an anti-clockwise direction.

### NOTE:

Handle printed parts with care as they are more fragile before post-exposure and avoid unnecessary exposure to light.

2. Grip the handles of the print platform securely and gently pull towards you to remove it.

### NOTE:

After removing the print platform from the printer, it can be helpful to tilt it and hold it over the vat to drain the excess resin. When carrying a finished print to your cleaning station, use paper towel or a suitable tray to catch any drips.

### WARNING:

Do not take printed parts off from the platform prior to the cleaning and post-curing steps. If removed, it may affect the dimensional accuracy of parts.

3. Place the platform into the Air Wash L using the specifically designed attachment.

4. Please refer to Photocentric Resin/ Resin Cleaner TDS for guidelines on wash cycle time recommendations.

- [Photocentric Resin Cleaner 30 TDS](#)

5. Parts can be cleaned in 10 minutes using Photocentric Resin Cleaner 30. Refer to Resin TDS for recommended cleaning cycles.

6. Once the print has been washed, rinse using water to remove excess resin and solvent. For Photocentric Resin Cleaner, rinse using hot water. For Photocentric Resin Cleaner 30, rinse using warm water.

7. Photocentric highly recommends using compressed air to dry parts thoroughly. Alternatively, leave rinsed parts aside to dry.

### NOTE:

Please refer to Section 8 for guidance on curing printed parts.

The cleaning process is imperative for the quality of surface finish and texture after post exposure. For further information on safe disposal of saturated resin cleaner and guidance on cleaning the wash unit, please refer to the Air Wash L User Manual.

### WARNING:

Wear gloves and safety glasses when working with Photocentric Resin Cleaners.

Photocentric Resin Cleaners and Airwash L can be purchased [here](#)

The Airwash L User Manual can be downloaded from the support page [here](#).

Here you can find guidance on installation, cleaning and emptying resin, and overall usage.

## 8. FINISHING PRINTS

All parts produced using Liquid Crystal Magna will need to be finished using UV light and heat to fully cure the resin and achieve the correct material properties. Photocentric recommends using the Photocentric Cure L2. Please refer to specific resin TDS information for guidelines on post exposure timings on the Photocentric website Daylight Resins [here](#).



1. Switch on the Cure L2 using the power switch at the front.
2. Please refer to resin TDS for guidelines on time recommendations for curing
3. Set the desired temperature and allow the Cure L2 to reach the desired temperature.
4. Slot the print platform into the Cure L2 with parts facing down, ensuring that the handles slot into the attachment.
5. Press and hold the 'Start' button (up arrow). The timer will beep once the time has elapsed.
6. Remove the platform from the Cure L2.

**NOTE:**

Wear gloves when handling printed parts prior to finishing. Handle the parts with care.

Photocentric Cure L2 can be purchased from this [webpage](#)

The user manual for Cure L2 can be downloaded from this [webpage](#)

**Cure L2**

External dimensions are:  
700 (W) x 600 (D) x 700 (H) mm.  
Internal dimensions are:  
500 (W) x 350 (D) x 550 (H) mm.

Parts should be cured on the platform to maintain dimensional accuracy.

Photocentric Cure L2 can be purchased from this [webpage](#).

The user manual for the Cure L2 can be downloaded from this [webpage](#), or, from LC Magna Resource Hub.

Here you can browse guidance on the following:

- Using your cure unit
- Programs
- Maintenance
- Environmental Operating Conditions

### 8.1 REMOVING PARTS FROM THE PRINT PLATFORM

To remove parts from the print platform, Photocentric recommends submerging the hot print platform into cold water (thermal shocking) or manually removing parts via cutting or scraping. The chosen method will depend on the compatibility of the resin, accessibility of supports, and contact area of the part to the platform.

**WARNING:**

The print platform will be hot to the touch after the curing process. It is important to wear heat-resistant gloves when removing the platform from the cure unit.

**Thermal Shocking**

1. Upon removing platforms from the cure unit, immediately submerge fully in cold water.
2. Parts will become free from the print platform.

**Manually Removing Parts**

If the printed resin is not compatible for thermal shocking, use cutters to remove the supports from the part. Alternatively, use the provided scraper to remove supports from the feet.

After the parts have been removed from the print platform, fully remove the supports from the part.

## 9. HOUSEKEEPING

### 9.1 REMOVING RESIN FROM VAT

1. After printing, resin should be removed from the vat to ensure there are no fragments of cured resin before printing again or changing to a different resin to print.
2. Take the resin bottle used for the previous print and remove the cap.
3. Set up a funnel and filter in the neck of the bottle.
4. Carefully remove the resin vat from the printer.
5. Tilt the vat towards the corner with the pouring spout and pour the resin through the filter and back into the bottle, be careful not to allow the paper filter to overflow.
6. Once most of the resin has poured away, use the vat cleaning tool to guide the remaining resin to the corner of the vat.
7. Clean off any resin drips on the outside of the vat with paper towel.
8. Place vat on suitable clean, smooth surface (e.g. vat cleaning foam mat).
9. Use paper towel to soak up the last of the resin in the vat.
10. Use a small amount of suitable cleaning solvent along with paper towel to clean the vat film and vat walls. Dry them thoroughly.
11. Check for any fragments of cured resin remaining on the vat film, dislodge them with care using the soft spatula provided.

12. Give the outside of the vat a final clean and check the film for signs of damage or wear, if you have any doubt about the condition of the vat film, refer to Section 10.1.

**NOTE:**

Printing with a damaged vat will cause failures and leaks causing permanent damage to the printer.

13. Check the screen of your Liquid Crystal Magna for any sign of resin contamination or damage.

14. If resin is present, clean thoroughly using paper towel, this is a sign that the film on the resin vat most likely needs replacing.

**NOTE:**

If you believe your printer's screen may be damaged, contact your supplier or visit the support pages of the Photocentric website.

15. Store the resin vat in the printer when not in use.

### 9.2 MAINTAINING PRINT PLATFORM

After printed parts have been harvested, it is vital that the print platform is cleaned thoroughly before being used again.

1. If any Photocentric Resin Cleaner or residual resin is left on the print platform, clean it off with a suitable cleaning solvent and paper towel.
2. Cured resin should be removed from the platform using the scraper provided.

**NOTE:**

Observation of burrs or pickups on the platform indicate that it will need to be sanded. The sanding should be minimal to avoid degrading the surface of the platform and its parallelism. Photocentric recommends using 60 grit sanding paper.

3. Ensure there is no cured resin blocking the holes in the platform as this will affect future prints.

4. If available, use compressed air to remove loose debris from the platform to avoid piercing the vat film for future prints.

5. When not in use, the platform should be stored inside of the printer.

## 10. MAINTENANCE

### 10.1 REPLACING THE RESIN VAT FILM

In normal operation, you should replace the resin vat film and gasket after approximately 20 prints. You should immediately replace the film if there is any visible damage or evidence of resin leakage. Replacing the vat film will take approximately 40 minutes if the correct procedure is followed and the correct tools are used. It is important to clean the vat body thoroughly to avoid fragments of cured resin or other contaminants damaging the newly fitted film. A video for Replacing the Resin Vat Film is available [here](#).

You will need:

- Vat Cleaning Foam Mat
- Paper Towel
- Cleaning Solvent (e.g. Isopropyl Alcohol)
- Scraper
- 1x Vat Film
- 1x Vat Gasket
- Pozi 1 Screwdriver
- Pozi 2 Screwdriver

1. Find a clean, flat surface to work on.
2. Use the vat cleaning foam mat provided to cover the surface and protect the vat from damage.
3. Clean the vat thoroughly to avoid dripping resin when the vat is turned over.
4. Turn over the vat.
5. Remove the large vat screws using the Pozi 2 Screwdriver, keep them to one side.
6. Lift off the vat ring assembly and remove the vat gasket.
7. Clean the vat body thoroughly, ensuring that no cured resin or other contamination is present on the surfaces that will contact the new film.
8. Remove the small vat screws using the Pozi 1 Screwdriver, keep them to one side.

9. Lift off the top vat ring with larger countersunk holes, remove the vat film and dispose of it.

10. Clean both vat rings thoroughly using paper towel and cleaning solvent.

11. Ensure the vat cleaning foam mat is clean.

12. Lay the bottom ring down facing upwards.

13. Take a new piece of vat film from the pack and lay it centrally over the ring.

14. Place the top ring onto the film with the countersinks facing upwards, aligning the holes with those on the bottom ring.

15. Secure the two rings together using the small screws and Pozi 1 Screwdriver. Now the vat ring assembly is ready for the next step.

#### NOTE:

The screws should pierce the film as you begin to tighten them. The film must be kept flat at all times. It should not be under tension but there must be no creases. There should be excess film on all sides of the rings.

16. Carefully pierce holes for the larger vat screws using the tip of the screwdriver.

17. Apply a new vat gasket to the frame of the vat and ensure the holes are aligned.

18. Place the vat ring assembly on top of the vat gasket with the countersinks facing upwards.

19. Secure the vat ring assembly to the vat body using the larger vat screws with the Pozi 2 screwdriver.

#### NOTE:

Tighten the screws in two phases. Fit all screws loosely before fully tightening any. In both phases, start with the corners, then the middle of each edge. Finish the remaining screws in opposite pairs.

20. Carefully cut away the excess film.

21. Check that the vat ring assembly sits flat against the vat body with no visible gaps.

22. Check that no damage has been caused to the new film during the assembly process.

23. The vat is ready to use.

#### NOTE:

You can gently tap on the vat film with a fingertip (not a fingernail) to check the tension. There should be a high-pitched, resonant sound like a small drum. If the film feels loose, the vat will not function properly.

### 10.2 PRINT PLATFORM RE-CALIBRATION

The print platform has been pre-calibrated on our production line according to strict QC procedures. This ensures that the bottom surface of the print platform is parallel with the LCD screen. The platform should not become misaligned during your time using Liquid Crystal Magna. However, misalignment can happen if the print platform is dropped, specific bolts are loosened etc.

Should there be a requirement for print platform re-calibration, please contact our Support Team for further guidance.

European & Asia Pacific Customers:

[support@photocentric.co.uk](mailto:support@photocentric.co.uk)

North & South American Customers:

[3Dsupport@photocentricusa.com](mailto:3Dsupport@photocentricusa.com)

### 10.3 GENERAL MAINTENANCE

#### Pre-Print Preventative Maintenance

Task	Frequency	Reference
Inspect print platform	Before each print	Inspection: Section 6 Cleaning: Section 9.2
Inspect LCD screen protector	Before each print	Inspection: Section 6
Inspect vat film	Before each print	Inspection: Section 6
Reskin (Replace) vat film	Approx. after 20 prints*	Vat reskinning: Section 10.1

\*Vat film may need to be replaced sooner in the case of damage or piercing or becomes too loose

#### Planned Maintenance

Task	Frequency	Reference
Test Blow-Peel functionality	Weekly	Magna Resource Hub
Test LEDs and LCD screen functionality	Weekly	Magna Resource Hub
Inspect vat film	Before each print	Inspection: Section 6
Reskin (Replace) vat film	Approx. after 20 prints*	Vat reskinning: Section 10.1
Clean fan filters	Monthly	Magna Resource Hub
Check torque on Z-Axis carriage bolts	Monthly	Magna Resource Hub
Check ball screw and rails for signs of oxidation	Bi-Monthly	Magna Resource Hub
Replace LCD screen protector	Every 3 to 6 months*	Magna Resource Hub
Re-homing Z-Axis arm and build plate	-	Photocentric Technical Support for details

#### NOTE:

\*LCD screen protector may need be changed earlier if there are excessive scratches. If the LCD screen protector is ever pierced, it should be replaced **immediately**.

## 11. USEFUL LINKS & RESOURCES

#### General Support

[LC Magna Resource Hub](#)

[LC Magna Installation Guide](#)

[Cure L2 Installation Guide](#)

[Cure L2 Manual](#)

[Air Wash L Installation Guide](#)

[Air Wash L Manual](#)

[Photocentric Studio Support Page.](#)

Download the latest version of Studio & read through the software guide

Best Practices for Supporting- Guidelines for supporting your part in Photocentric Studio

[Daylight Resin & Resin Cleaner Technical Data.](#)

Contains Technical Data Sheets that give information on material properties, wash, and cure times, as well as Safety Data Sheets that list important safety information.

[General Printing Troubleshooting](#)

[LC Magna Support Hub- Maintenance](#)

[3D Store](#)